



Digital Lighting Systems, Inc.

SC804

8 Channel Super Chaser
and Speller

8 x 4 amp Outputs

SC804-12/SC804-24/SC804-120/SC804-220

(SL804 Wiring Instructions Included)

DMX & Animation

USER'S MANUAL

General Description

The SC804 is an eight-channel single-phase AC lighting controller capable of producing dazzling and spectacular light shows.

It consists of three circuit boards, the INT16 logic board, a slave INT-SL board with LED output emulators for circuits 5-8, and the LDM load driver module board. The INT16 and LDM circuit boards are interconnected by a 10-conductor low-voltage cable (LVC). The INT16 and INT-SL are interconnected by a 6-conductor low-voltage cable (LVC2).

A functional block diagram of the SC804 is shown in Figure 1. The LDM board contains the equivalent of eight solid-state relays (SSR). The LDM is configured as two sets of four relays, with each set of four sharing one power line feed. Each relay is rated at a maximum output current of 4 Amperes. The SSR relays are controlled by low-voltage DC signals from the INT16 SC logic board. These signals are optically-isolated by the LDM circuitry from all line voltage elements. The INT16 logic board contains a powerful microprocessor programmed to generate 16 user-selectable light sequences or patterns at an adjustable rate (the SC804 is also available with a "SPELLER" pattern or custom patterns upon request). A rotary selector on the INT16 is used to select the chase pattern and a second one is used to set the rate or chase speed. Patterns and speed can be monitored by eight LED's that represent the outputs of the SC804. The INT16 and INT-SL are mounted on the back of the front cover and derive their power from the 10 VAC step down transformer located on the LDM circuit board. All controls are accessible at the front panel. A single SC804 Master can drive an additional SI804 slave in order to meet higher load requirements.

Please contact the factory for additional information by telephone 1-877-264-8391 or email info@digitallighting.com

Table 1 - Terminals Definition

NAME	DESCRIPTION
1	Output Of Solid-State Relay #1
2	Output Of Solid-State Relay #2
3	Output Of Solid-State Relay #3
4	Output Of Solid-State Relay #4
5	Output Of Solid-State Relay #5
6	Output Of Solid-State Relay #6
7	Output Of Solid-State Relay #7
8	Output Of Solid-State Relay #8
H1	Hot Line Feed For Relays 1, 2, 3 & 4
H2	Hot Line Feed For Relays 5, 6, 7 & 8
N1-N8	Neutral Bus Connections.

Table 2 - Absolute Maximum Electrical Ratings

Electrical Characteristic	Terminal	Maximum
Relay Load Current	1 to 8	4 Amps.
Input Current For Relays 1 - 4	H1	20 Amps.
Input Current For Relays 5 - 8	H2	20 Amps.
Input Voltage	H1-H2	240 VAC, 1-Phase.

NOTE

Line Inputs H1 and H2 must be on the same electrical phase.

Figure 1 - SC804 Functional Block Diagram

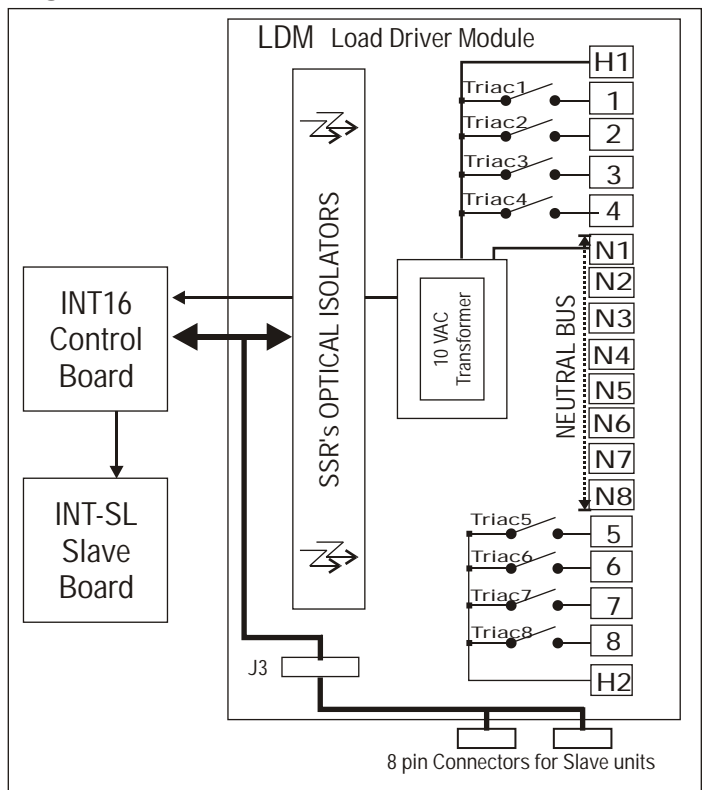

Figure 2 - SC804 Detail

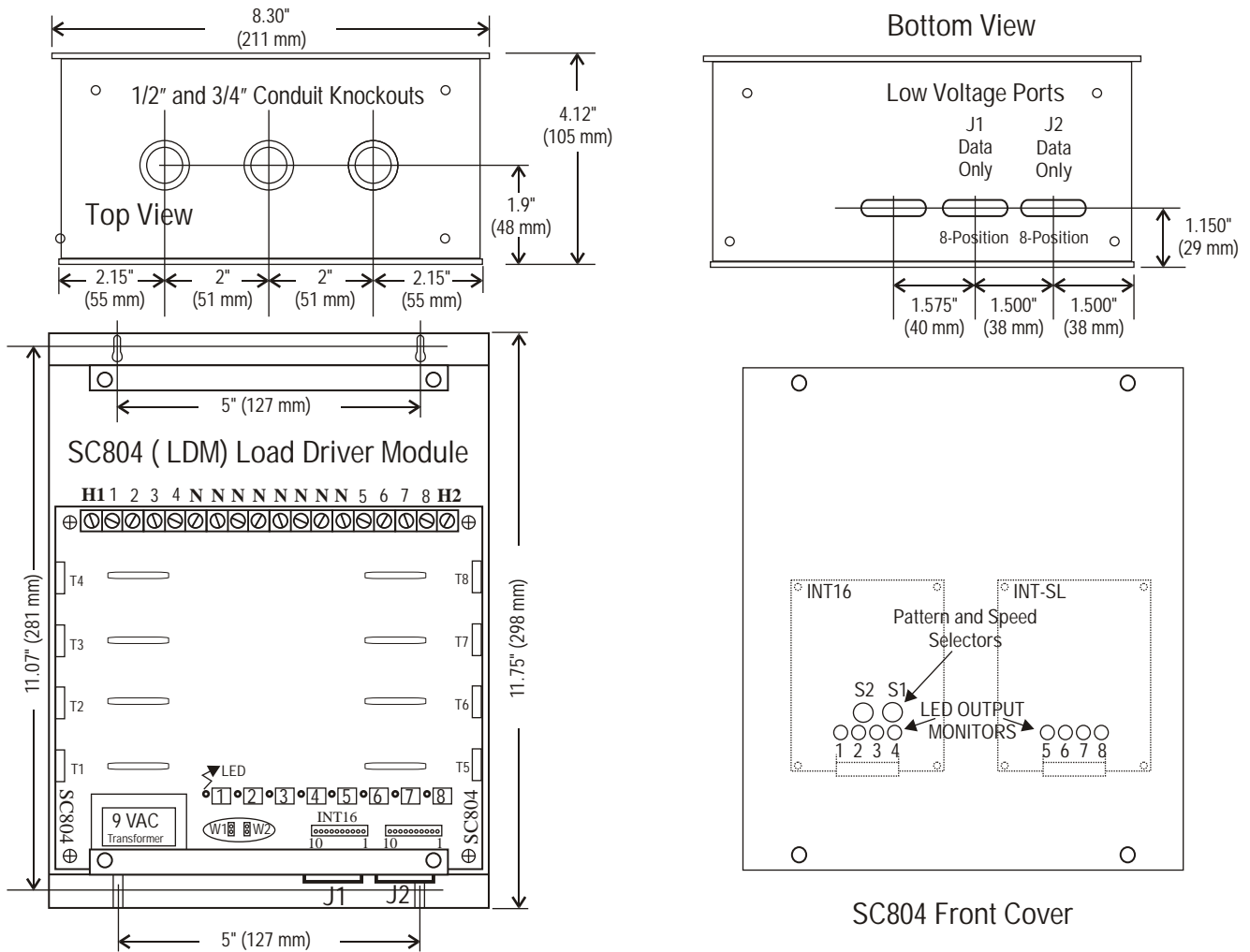

Figure 3 - SC804 INT16 and INT-SL Detail

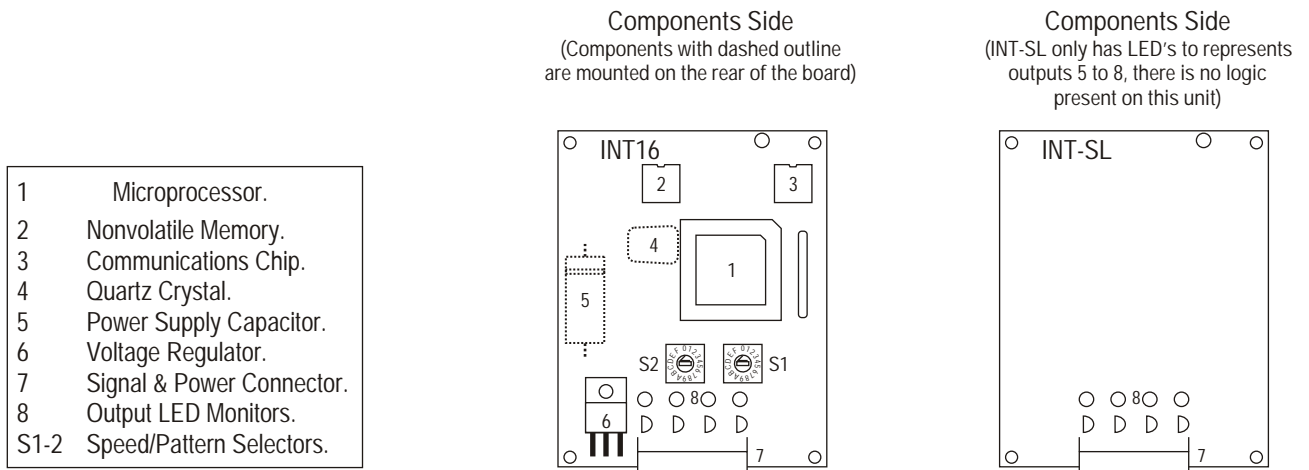

Table 3 - INTO4 Circuit Legend

A- ENCLOSURE INSTALLATION

Install the SC804 enclosure in a well ventilated area where the ambient temperature will remain between 40°F and 104°F for full load operation. The enclosure location can be near the electric service panel or close to the loads, whichever is more convenient.

B- LINE VOLTAGE WIRING

(Please refer to Figures 5, 6 & 7)

All Line and Neutral wires must have adequate gauges to carry the load and the common currents.

All wires must have Copper Conductors with 90°C Wire Insulation.

- Select two 20-Amp. breakers from the same 120 VAC phase in the service panel.
- Connect the above breakers to terminals H1 & H2 respectively. If the total load does not exceed 16 Amps., a single breaker may be used and terminals H1 & H2 may be jumpered together with a #12 AWG wire.
- Connect 2 Neutral wires from the service panel to N3 & N4 respectively.
- Bring a Common wire and a Return wire, from each of the loads to the SC804. A single Common wire may be used provided the wire gauge is adequate for carrying the required total load current.
- Connect the Common wires from load #1 through load #8 to any position on the Neutral Bus (N1 - N8).
- Connect the Return wires from load #1 through load #8 to terminals 1 through 8 respectively.

C- MASTER-SLAVE SYSTEM WIRING

The SC804 can control an additional SL804 slave. The slave contains the Load Driver Module (LDM) without the INT16 logic control board. This configuration is helpful when the load capacity of the SC804 master is exceeded and all loads must be synchronized together. The slave is daisy-chained to the master via two low-voltage 5-conductor cables (JJ88) provided by the factory. The SC804 and SL804 are wired identically.

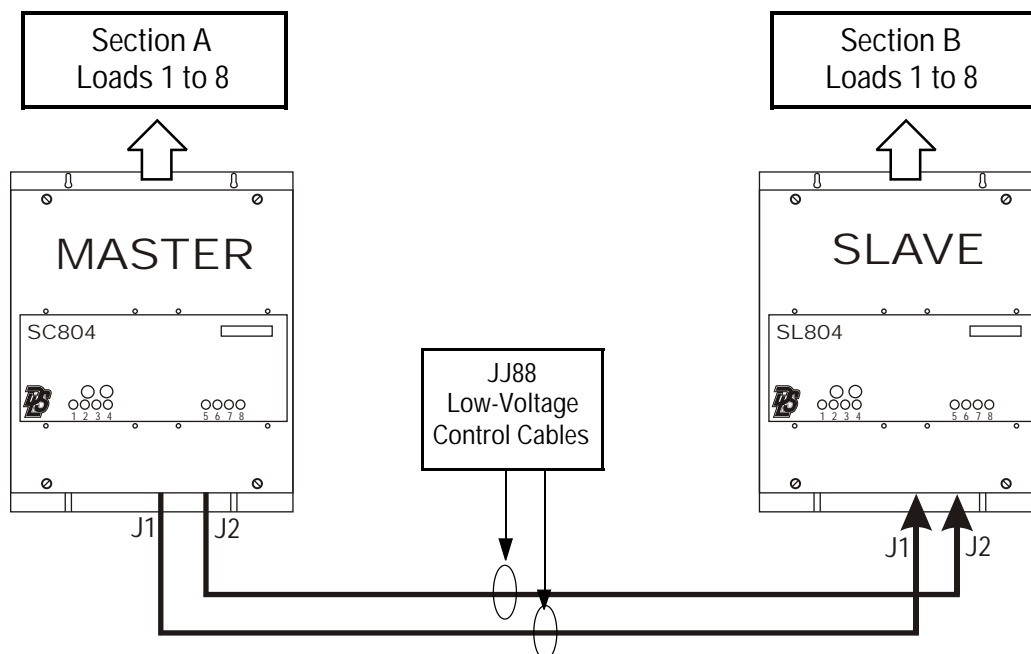

Figure 4 - SC804 to SL804 - Master/Slave Connection

SC804-120 General Wiring Instructions for 120V version.

Wiring Notes

- DO NOT EXCEED 480 W (4 Amps.) per circuit output @ 120VAC.
- SC804 chaser packs may be fed by one or two 20 A (maximum) branch circuits and may have up to eight separately switched loads.
- Both breakers must be on the same power phase.
- CAUTION: DO NOT attempt to parallel outputs to increase capacity.
- Installations must conform to local and/or NEC code requirements.
- Each load must have its own Neutral wire for full load operation.
- All line voltage wires must have copper conductors of adequate Gauge with 90° C wire insulation.

NOTE

The SL804 output wiring is identical to the SC804. SL804 slaves do not have the INT16 control board. The SL804 Load Driver Board (LDM) does not have a transformer.

Figure 5 - SC804 Typical 120 VAC Wiring.

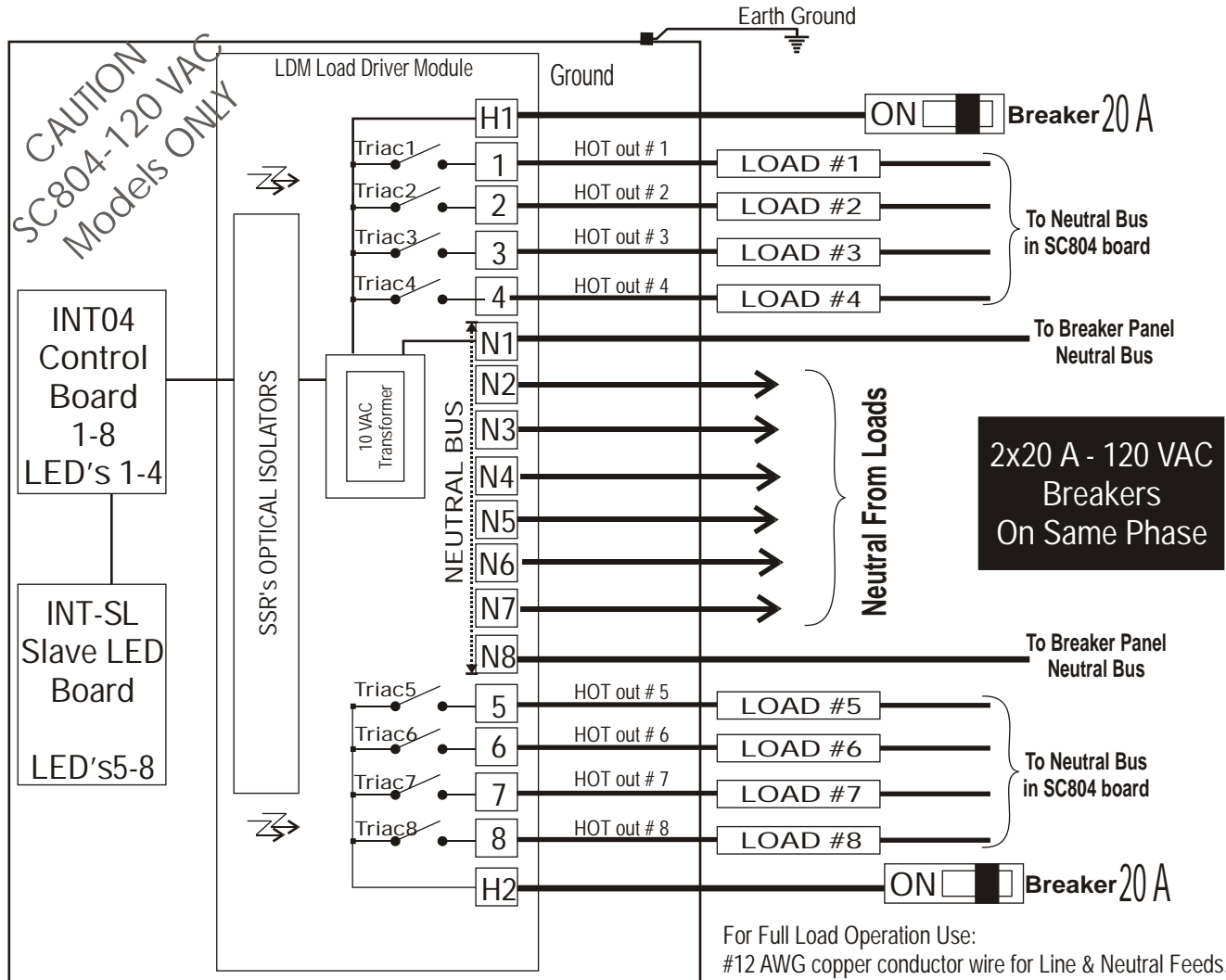

SC804-220 General Wiring Instructions for 220/240V version.

Wiring Notes

- DO NOT EXCEED 880W (4 Amps.) per circuit output @ 220VAC (or 960W @ 220VAC).
- SC804 chaser packs may be fed by one or two 20 A (maximum) branch circuits and may have up to eight separately switched loads.
- Both breakers must be on the same power phase.
- CAUTION: DO NOT attempt to parallel outputs to increase capacity.
- Installations must conform to local and/or NEC code requirements.
- Each load must have its own Neutral wire for full load operation.
- All line voltage wires must have copper conductors of adequate Gauge with 90° C wire insulation.

NOTE

The SL804 output wiring is identical to the SC804. SL804 slaves do not have the INT16 control board. The SL804 Load Driver Board (LDM) does not have a transformer.

Figure 6 - SC804 Typical 120 VAC Wiring.

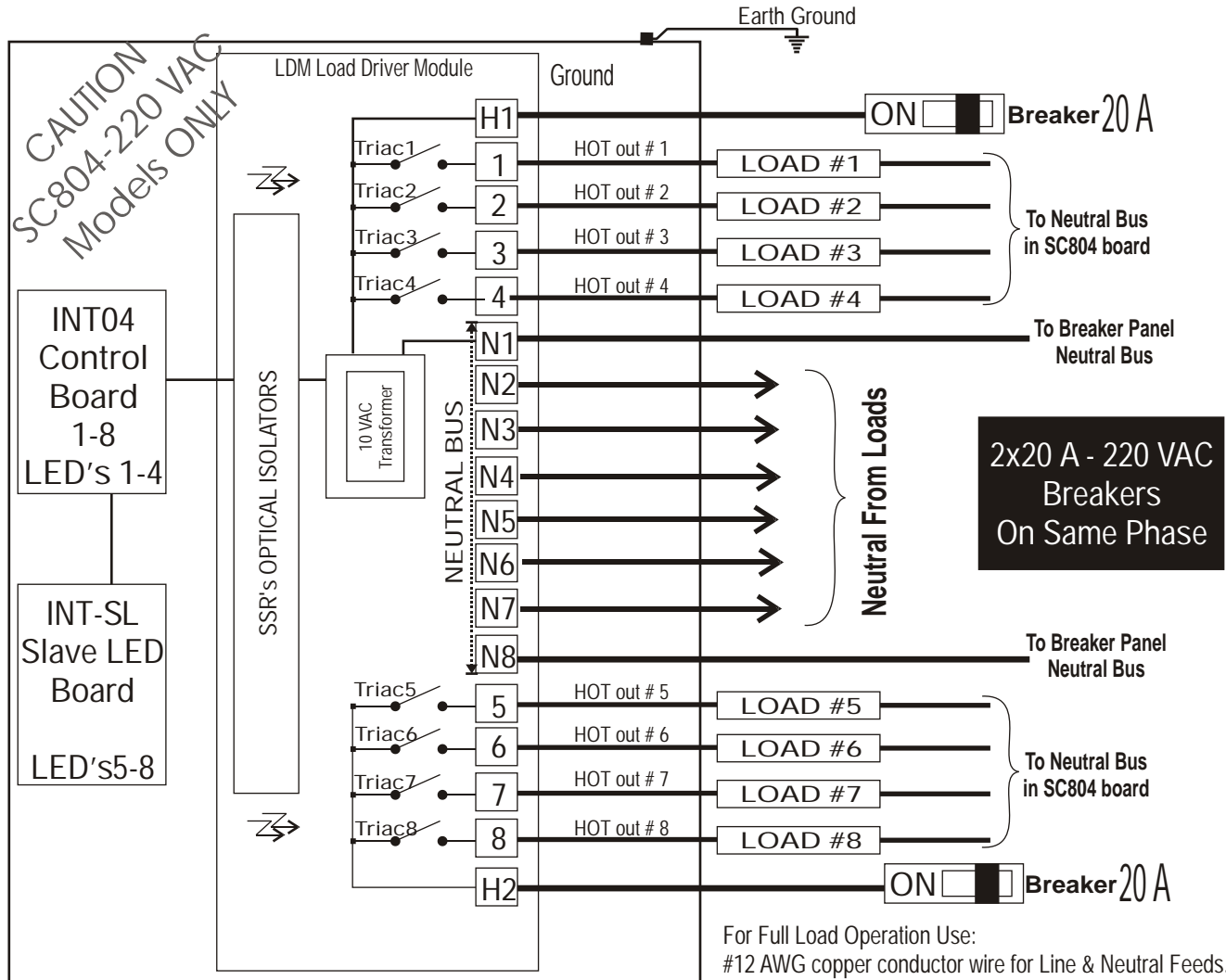
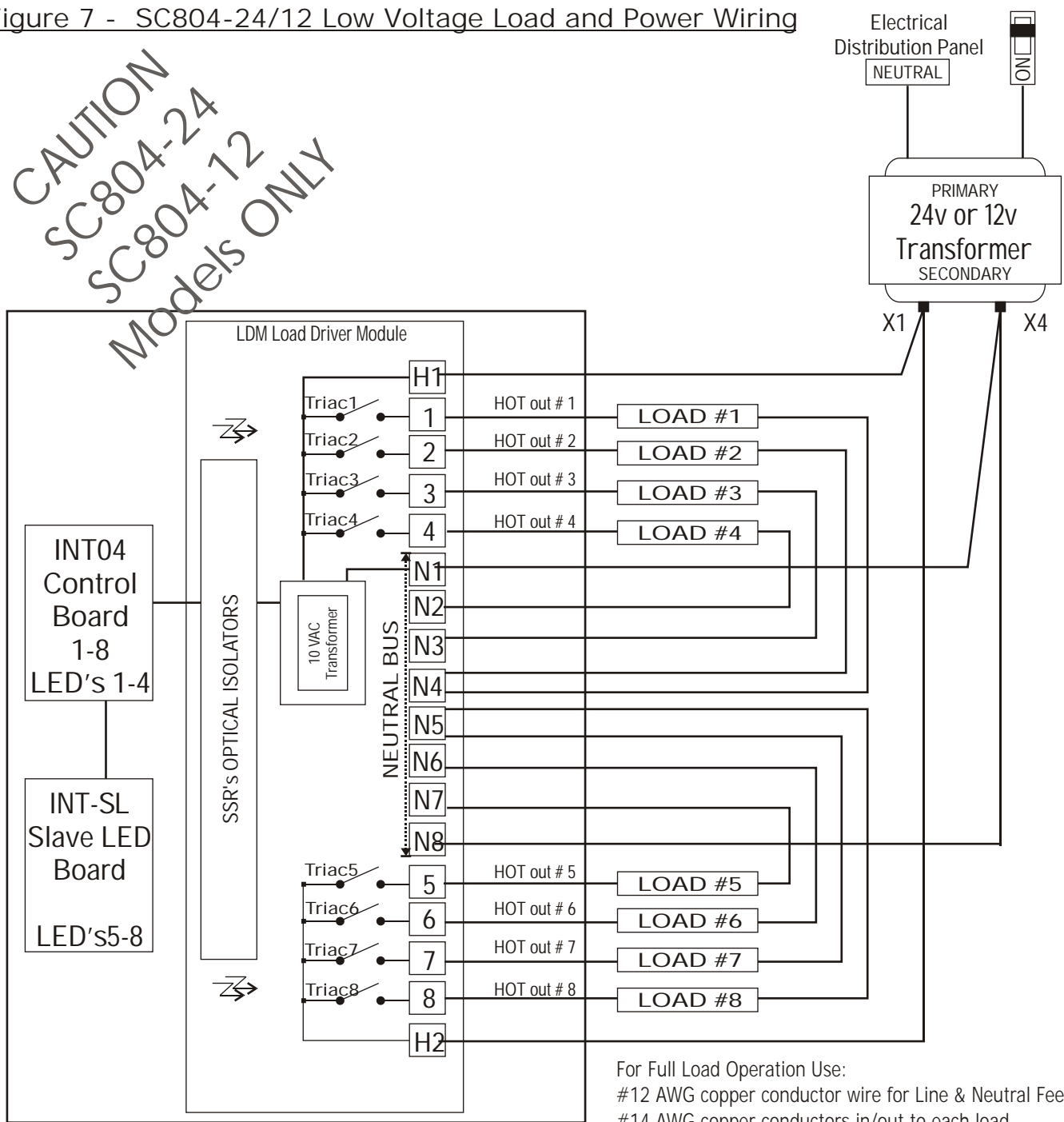

Figure 7 - SC804-24/12 Low Voltage Load and Power Wiring

CAUTION
SC804-24
SC804-12
Models ONLY



For Full Load Operation Use:
#12 AWG copper conductor wire for Line & Neutral Feeds.
#14 AWG copper conductors in/out to each load.
Max. Load per circuit : 4 Amperes (96W at 24 VAC).

NOTES

- 1 With SC804-24 you may use a single 24 VAC-800 VA or better transformer or two separate 24 VAC-400 VA or better transformers.
- 2 With SC804-12 you may use a single 12 VAC-400 VA or better transformer or two separate 12 VAC-200 VA or better transformers.
- 3 Follow transformer's installation & wiring instructions from manufacturer.
- 4 Maximum Load Per Output: 48 Watts at 12 VAC.
- 5 Maximum Load Per Output: 96 watts at 24 VAC.

Controls

The controls consist of two rotary 16-position (0-9 and A-F) selectors. S2 (Mode) is used for selecting the desired chase pattern. Positions 0 and F contain special patterns. The SC804 outputs can be turned to static ON by selecting F. When 0 is selected, the SC804 goes into an automatic pattern change mode. All other positions cause the SC804 to play a single pattern indefinitely. S1 is used to select one of 16 individual chase rates (Rate). Minimum speed is achieved by selecting position 0. Speed doubles with each subsequent selector position.

Indicators

LED indicators 1 to 8 indicate the status (On-Off) of their corresponding outputs.

Figure 9 - SC804 Front Panel Indicators and Control Selectors

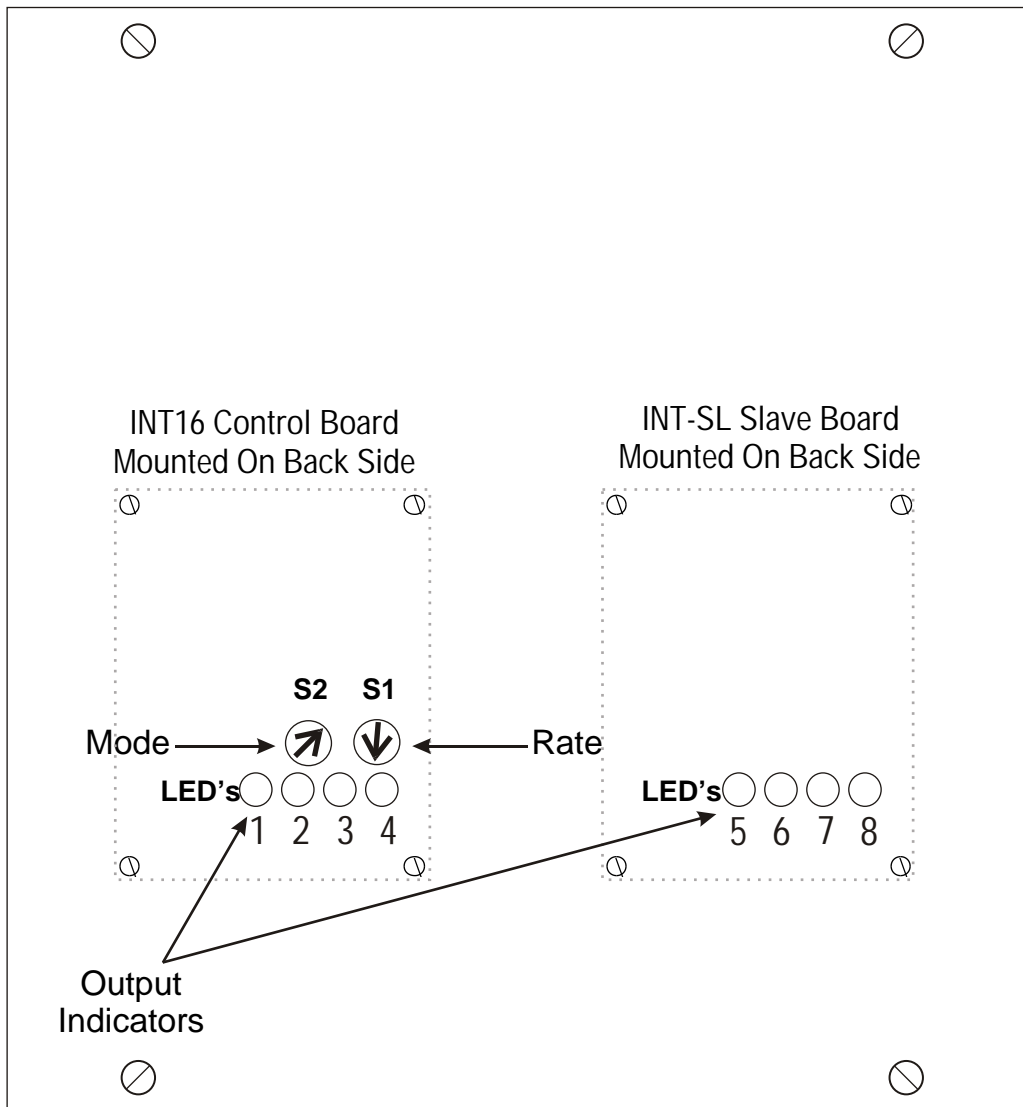

CAUTION

Use a small screw driver for adjusting selector positions in order to avoid damaging the tips.

SC804 Patterns

(Continued on Page 9)

1

Light Chase

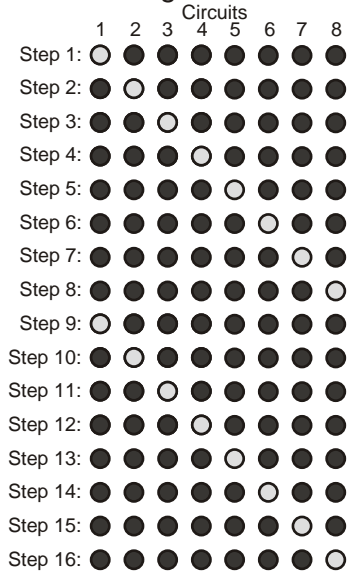

2

Fill & Swipe Forward

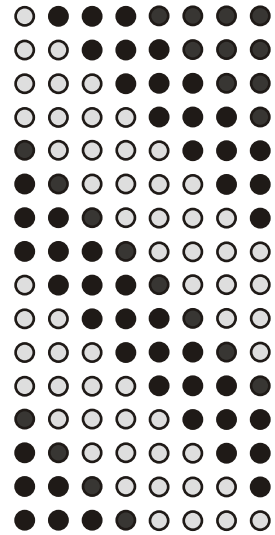

3

Fill & Swipe Back

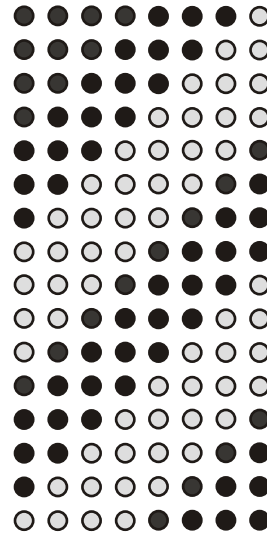

4

Light Bounce

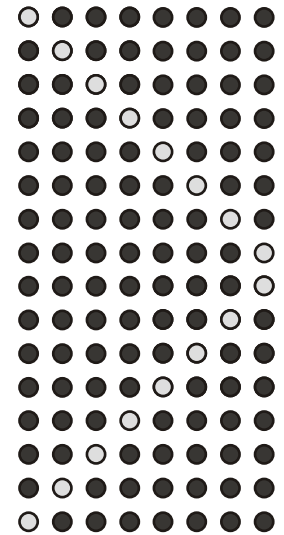

5

Dark Bounce

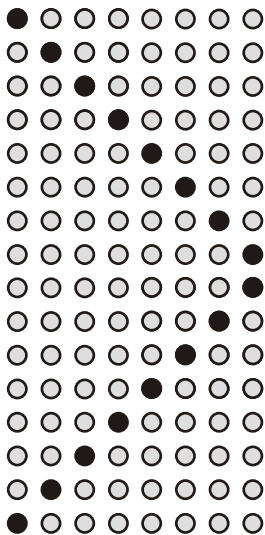

6

Dark Chase

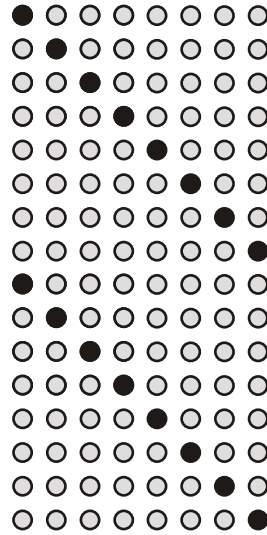

7

Flip-Flop

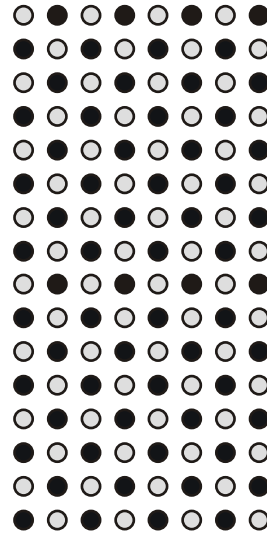

8

Flash All

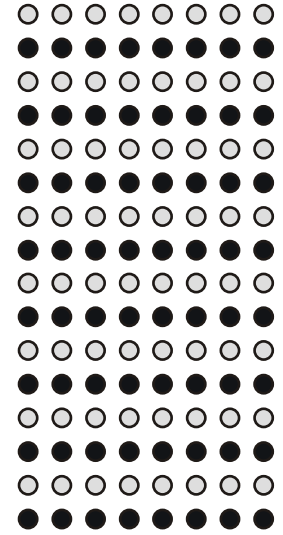

KEY: ○ ON
● OFF

SC804 Patterns Cont'd

9

Flash Light Chase

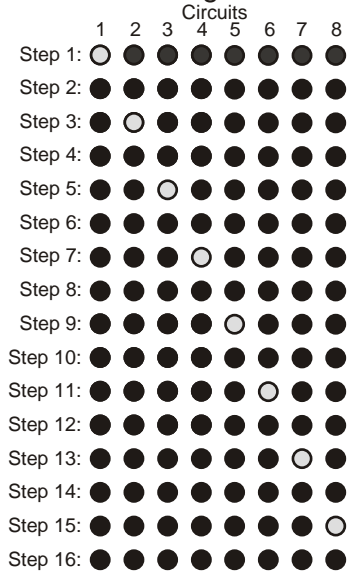

A

Spring Forward

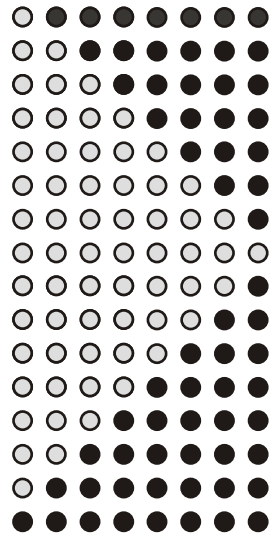

B

Spring Back

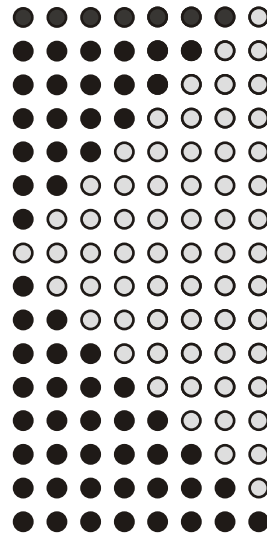

C

Flash Dark Chase

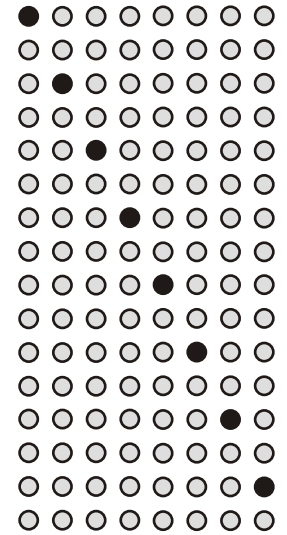

D

Crawl Forward

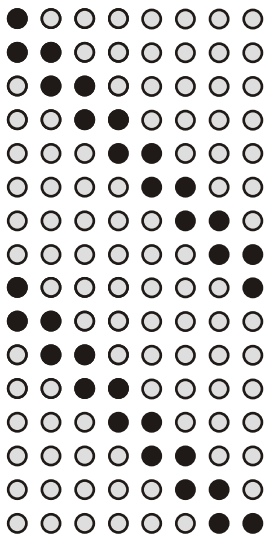

E

Crawl Back

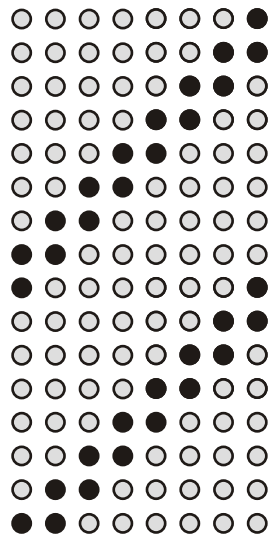

F

ALL ON

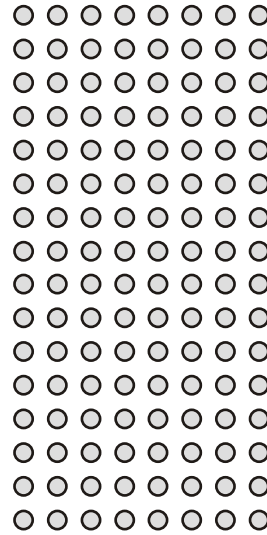

O

AUTO

Auto Cycle
Patterns 1-F
4 x each
then repeat





LIMITED WARRANTY

Digital Lighting Systems warrants to the purchaser that its products have been carefully manufactured and inspected and are warranted to be free from defects of workmanship and materials when used as intended. Any abuse or misuse contrary to normal operation shall void this warranty.

Digital Lighting Systems' obligation under this warranty shall be limited to replacement or repair of any units as shall within one year of date of invoice from Digital Lighting Systems, prove defective; and Digital Lighting Systems shall not be liable for any other damages, whether direct or consequential. The implied warranties of merchantability and fitness for a particular purpose are limited to the duration of the expressed warranty. Some states do not allow the exclusion of the limitation of incidental or consequential damages, so the above limitation or exclusion may not apply to you. This warranty gives you specific legal rights, you may also have other legal rights which vary from state to state.

Defective merchandise may be returned to Digital Lighting Systems, prepaid, after prior notification has been given and approval obtained for the return. To obtain prior approval for the return of the defective items, contact your local Digital Lighting Systems distributor, representative, or:

Digital Lighting Systems, Inc.
Attn: Customer Service Department
7588 NW 8th Street
Miami, FL 33126
(305) 264-8391

Upon request, replacement unit(s) will be shipped as soon as available. Unless immediate shipment of replacement merchandise is requested, Digital Lighting Systems will not ship replacement merchandise until defective merchandise is received, inspected, and determined to be defective.

No labor charges in connection with warranty problems will be reimbursed by Digital Lighting Systems without prior written approval from the factory.

Digital Lighting Systems distributors and representatives have no authority to change this warranty without written permission.

Digital Lighting Systems reserves the right to determine the best method of correcting warranty problems.





Digital Lighting Systems, Inc.
7588 NW 8th Street
Miami, FL 33126
www.digitallighting.com

Tel 305-264-8391
Fax 305-261-6637
e-m info@digitallighting.com

Printed in U.S.A.
April 2003