

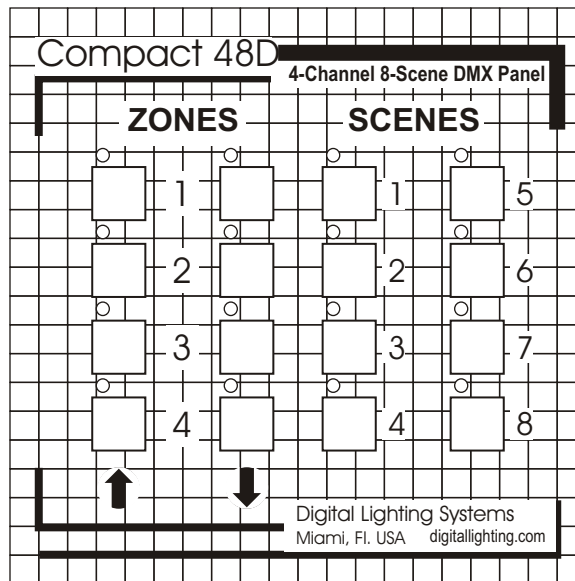

# Digital Lighting Systems, Inc.

## COMPACT-44/48D Series Four Zone/Multi-Scene Wall Box DMX Panels



### MODEL NUMBERS

- Compact-48D
- Compact-48D-AE
- Compact-44D

# USER'S MANUAL

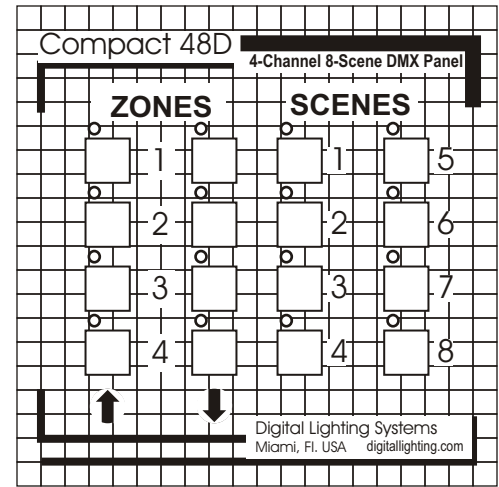
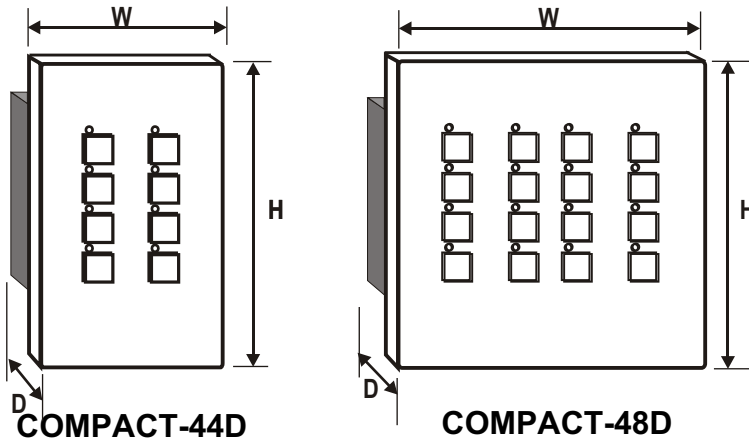

**INTRODUCTION**

The **COMPACT-48D** is a four-channel **DMX** dimmer control panel with 8 scene presets. It is designed to mount in a 2-gang masonry box and is also available in a table top aluminum enclosure. Each channel has a pair of control buttons, a **RAISE** and a **LOWER**, to adjust its **DMX** value. The **COMPACT-48D** features **PRESET** buttons for storing and recalling 8 separate lighting scenes. Preset scenes may be locked, once stored in the panel's non-volatile memory. The **COMPACT-48D** is one of the smallest and most unique 4-channel / 8-Scene **DMX** panel in the industry, requiring the same wall space as a standard heavy-duty wall box dimmer. (See masonry box dimensions on page 2.)

The **COMPACT-44D** is a four-channel **DMX** dimmer control panel with 4 scene presets. It is designed to mount in a single-gang masonry box. Each channel has a single control button that functions as a **RAISE** and a **LOWER**, alternately. The **COMPACT-44D** features **PRESET** buttons for storing and recalling 4 separate lighting scenes. Preset scenes may be locked, once stored in the panel's non-volatile memory. The **COMPACT-44D** is one of the smallest and most unique 4-channel / 4-Scene **DMX** panel in the industry, requiring the same wall space as a standard wall box toggle switch. (See masonry box dimensions on page 2.)

Fade Rate between scenes may be adjusted using a rotary selector on the back of the panels. The **COMPACT** Series is ideal for controlling the emerging new **DMX** compatible Fluorescent ballasts.

**GENERAL FEATURES**

- ◆ Economical.
- ◆ Compact Wall-Mount Panels.
- ◆ 4-Channel / 8-Scene Double-Gang Version.
- ◆ 4-Channel / 4-Scene Single-Gang Version.
- ◆ Simple Pushbutton Operation.
- ◆ Channel and Preset LED Indicators.
- ◆ Non-Volatile Memory Storage Of Scenes.

**APPLICATIONS**

- Office Buildings.
- Hotel Conference Rooms.
- Houses Of Worship.
- Schools and Universities.
- Museums and Art Galleries.
- Banquet Halls.
- Restaurants.

**Physical and Electrical Specifications**

Back Plate: Metal Construction.  
 Dimensions: See Table Below.  
 Power: Max. 80 mA at 10 VAC-50/60 Hz.  
 Data Output: RS485 Compliant.  
 Output Drive: **256 1/8 DMX Loads.**  
 Data Format: Standard DMX-512 Protocol.  
 Data Retention: 10 years, no batteries required.  
 ESD Protection: 15 KV on data input and output.

**PD408-DMX DIMMER PACK**

The **COMPACT-44/48D** require an external dimmer pack and a **DMX** cable. Any **DMX-512** compatible dimmer pack may be used. Digital Lighting Systems, Inc. manufactures high quality, low cost, **DMX-512** dimmer packs. The **PD408-DMX** is an excellent companion to the Compact-xxD panel. It can drive four 960 Watt 120 VAC loads at 50 and 60Hz. 12/24/ 220 VAC versions are also available.

**SERIES WIDTH HEIGHT DEPTH GANG**

SERIES	WIDTH	HEIGHT	DEPTH	GANG
COMPACT-44D	2.800" 071 mm	4.600" 117 mm	1.650" 042 mm	Single
COMPACT-48D	4.600" 117 mm	4.600" 117 mm	1.650" 042 mm	Double
COMPACT-48D -AE	4.600" 117 mm	4.600" 117 mm	2.500" 065 mm	Double

DEPTH (D) includes circuit board with components

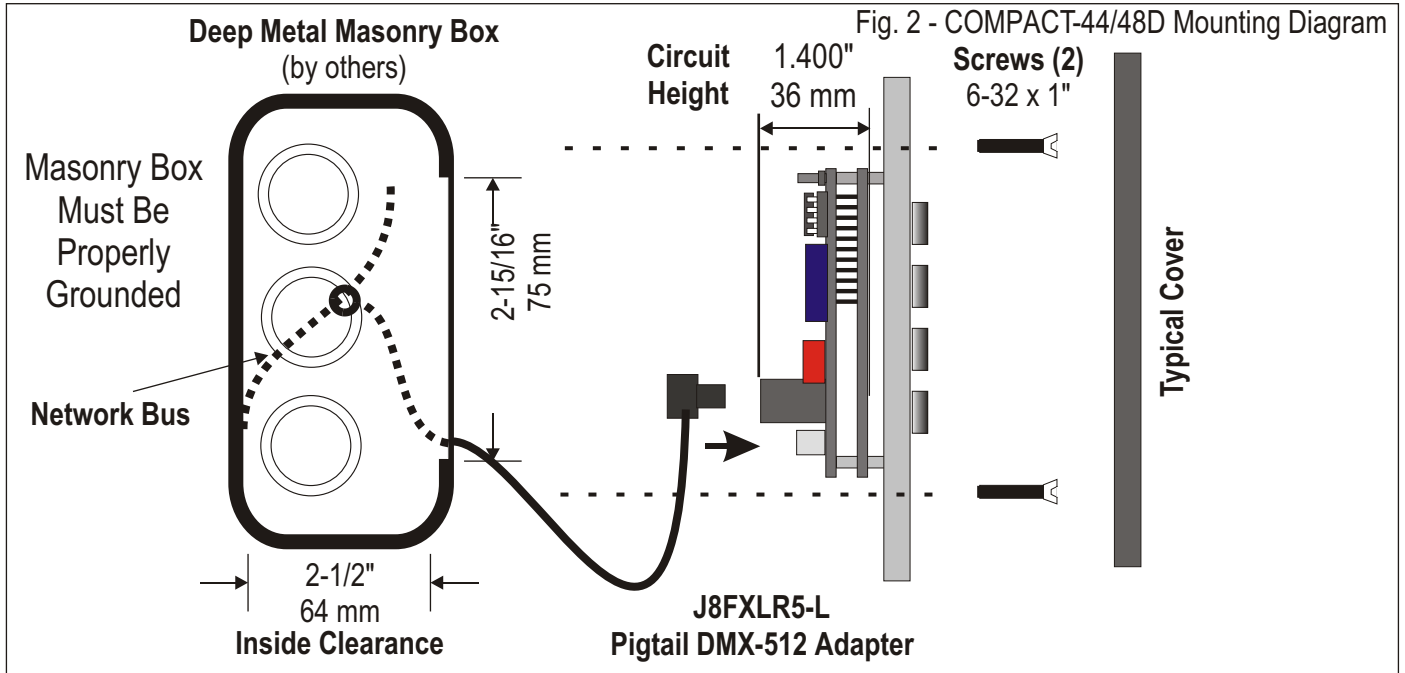

**Mounting requirements**

- The **COMPACT-48D** mounts in double-gang deep masonry box or may be ordered in a table top aluminum enclosure. The Female XLR connector comes mounted on the side of the enclosure. The **COMPACT-44D** mounts in a single-gang masonry box.
- Both types of masonry boxes must have a minimum depth of 2-1/2" and a minimum inside height of 2-15/16" to allow clearance for printed circuit board. (See above illustration.)
- Use Grounded metal boxes only.

**Ordering Information**

- COMPACT-48D:** 4-Channel / 8-Scene Panel, 2-G size.  
**COMPACT-48D-AE:** With Aluminum Table Top Enclosure.  
**COMPACT-44D:** 4-Channel / 4-Scene Panel, 1-G size.  
**J8FXLR5-L:** DMX-512 XLR Adapter Pigtail. (L= no. of feet).

**Wiring Notes**

- All wiring between the **COMPACT-44/48D** panel and dimmer packs is low voltage (NEMA Class 2) and must be a shielded twisted pair cable.
- Standard industry **DMX-512** cables may be used with the panel.
- Do not run DMX cable in the same conduit with non-class 2 circuits.
- The panels are supplied with an external low voltage wall adapter.
- Power for the adapter may be on a different power phase from power supplying the **DMX-512** dimmer packs or fixtures.
- Installation must conform to local and/or NEC code requirements.

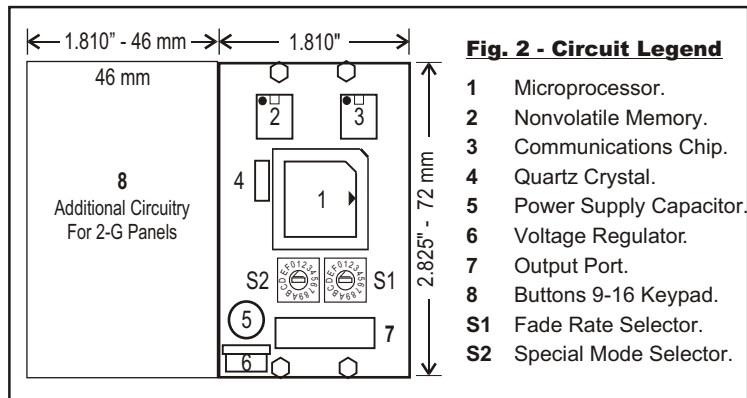

**Installation Instructions** ( See Figs. 3, 4 & 5 below).

1. Install the **COMPACT-44/48D** in a convenient location. Fig. 3 shows an **COMPACT-48D-AE** which has a female XLR connector mounted on the side of its aluminium enclosure. **COMPACT-48D** models may be mounted in deep double-gang masonry boxes and have a pigtail for data connections (See Fig. 5 below).
2. Provide a standard power outlet with a toggle switch for the wall transformer. Plug the supplied transformer to the **COMPACT-44/48D** using the Molex connector plugs. The **COMPACT-8D** may remain energized at all times.
3. Install the DMX dimmer pack and follow the wiring instructions in its user manual.
4. Connect the **COMPACT-44/48D** to the Dimmer Pack using the DMX cable (DMX-CC-LEN) to either internally mounted (**COMPACT-48D-AE**) or externally mounted XLR connector (**COMPACT-48D** on request and **COMPACT-44D**, see Fig.4). Skip to Operating Instructions.

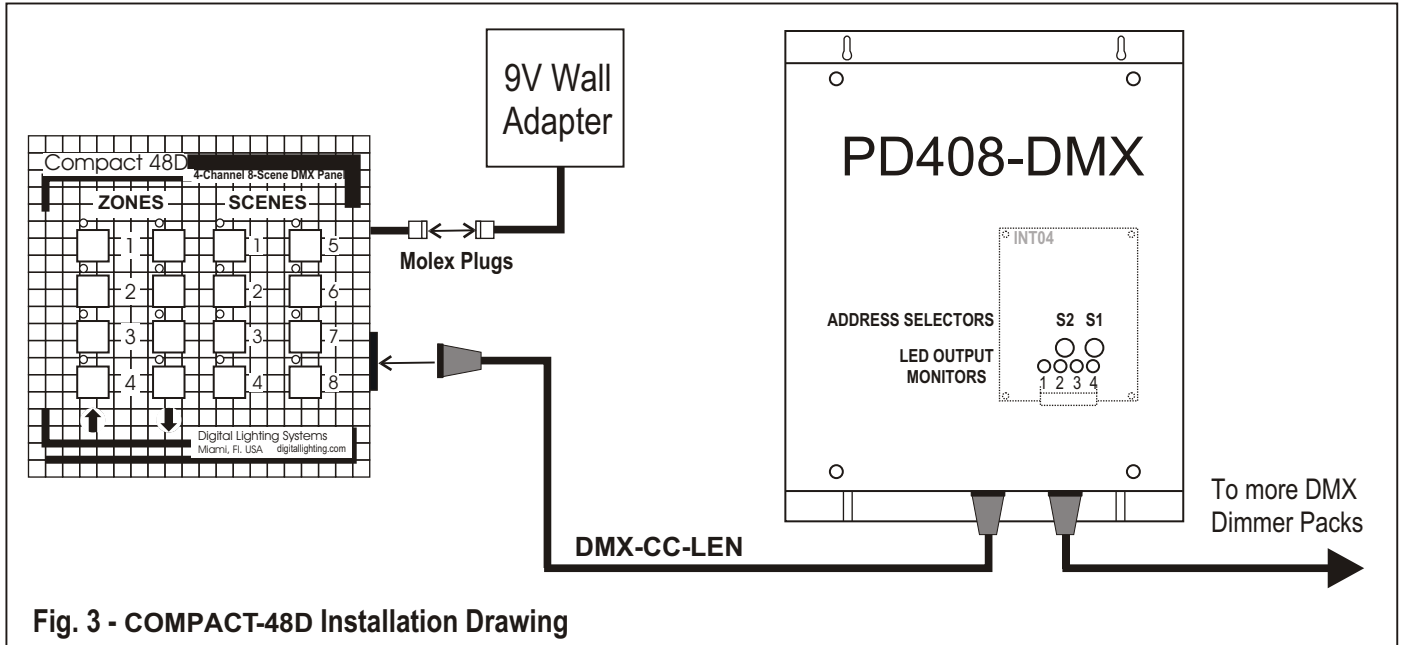
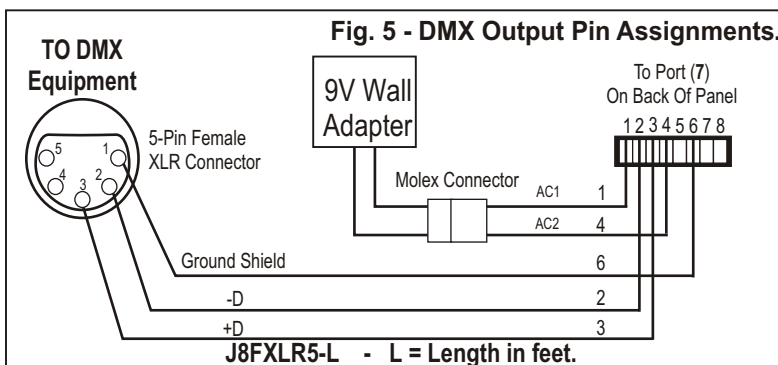

**Fig. 3 - COMPACT-48D Installation Drawing**

**COMPACT-44/48D DMX and Power Connections**

The **COMPACT-44/48D** panels use a standard 5-Pin Female XLR connector to connect to DMX equipment as seen in Figs. 4 & 5. They are also available on request with an unterminated pigtail that plugs into the back of the unit so that customer may make their own DMX connections, or with a pre-terminated cable with XLR connector to the customer's desired length (**J8FXLR5-L**). An external transformer supplies power via a 2-pos. Molex type connector.

Power and DMX pin assignments are shown in Fig. 5.



**Fig. 5 - DMX Output Pin Assignments.**

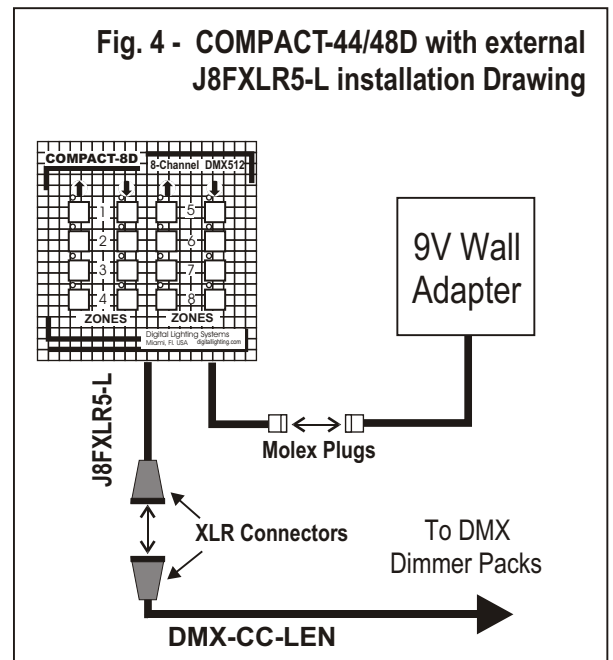

**Fig. 4 - COMPACT-44/48D with external J8FXLR5-L installation Drawing**

## Operating Instructions **COMPACT-48D**

### Four Channels, Eight Scenes

#### Adjusting Channel levels

Adjust channel levels by pressing and holding their respective up or down button until each level ramps up or down to the desired value. For fine adjustments, momentarily press and release the appropriate button. This limits changes in levels to an increment or a decrement of 1 step out of 256. The LED associated with the up button stays on when its corresponding level reaches 100%, while the down LED stays on when the level reaches 0%. Both LED's remain on otherwise.

#### Preset Scenes

*Presets must be un-locked to enable this operation (see paragraph below).*

To store a scene:

- 1- Adjust the channel levels for a particular scene number. 2- Press and hold the corresponding scene button. 3- When the panel's LED's flash, release the button.

To recall a scene:

- 1- Select the button of the scene you wish to recall. 2- Momentarily press and release the button. The LED associated with the preset button that was actuated last remains on while all others turn off.

#### Locking/Unlocking Presets

*Presets automatically re-lock upon panel reset or power-up.*

To Unlock and Enable Storing the 8 Presets:

- 1- Hold down the panel's RESET button (or de-energize panel).
- 2- Simultaneously press and hold-down preset buttons 4 & 8.
- 3- Release the RESET button ( or re-energize panel). LED's will flash once.
- 4- Release Preset buttons 4 & 8. LED's will flash again to indicate that presets have been unlocked.

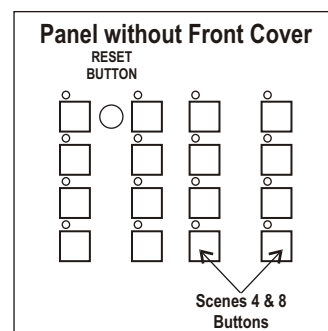

To Access RESET button gently pry front cover from panel, using a small tip screw driver applied to the notch located at the bottom.

## Operating Instructions **COMPACT-44D**

### Four Channels, Four Scenes

#### Adjusting Channel levels

Each of the four channels this unit controls has a corresponding button for raising and lowering that channel. Channel levels may be adjusted by pressing and holding their respective button until each level ramps up or down to the desired value. For fine adjustments, momentarily press and release the appropriate button. This limits changes in levels to an increment or a decrement of 1 step out of 256. Pushing and holding a button causes the level of the corresponding output to vary in one direction. Releasing the button and pressing again causes the output level to vary in the reverse direction.

#### Preset Scenes

*Presets must be un-locked to enable this operation (see paragraph below).*

To store a scene:

- 1- Adjust the channel levels for a particular scene number.
- 2- Press and hold the corresponding scene button.
- 3- When the panel's LED's flash, release the button.

To recall a scene:

- 1- Select the button of the scene you wish to recall. 2- Momentarily press and release the button. The LED associated with the preset button that was actuated last remains on while all others turn off.

*Presets automatically re-lock upon panel reset or power-up.*

To Unlock and Enable Storing the 4 Presets:

- 1- Hold down the panel's RESET button (or de-energize panel).
- 2- Simultaneously press and hold-down buttons 4 & 8.
- 3- Release the RESET button ( or re-energize panel). LED's will flash once.
- 4- Release buttons 4 & 8. LED's will flash again to indicate that presets have been unlocked.

#### Panel without Front Cover

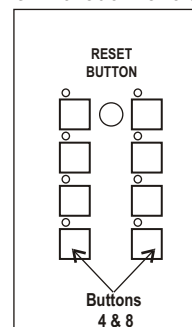

To Access RESET button gently pry front cover from panel, using a small tip screw driver applied to the notch located at the bottom.

## Scene Fade Rate Instructions COMPACT-44/48D

### Scene Fade Rate Selection

The fade rate between scenes is adjustable using rotary selectors S1 and S2 (See Fig.7 below for S1 and S2 locations). With S2 set to position "0", fade times from 8.43 to 40.06 sec's. may be achieved (See Table 1). Faster fade rates may be achieved by setting S2 to position "F" (See Table 2). However, DMX dimmer packs not manufactured by DLS may not operate properly in this mode. Setting S2 to position "F" causes the **COMPACT-44/48D** controllers to output a 4-byte DMX packet on channel addresses 1 to 4 only. The PD408-DMX dimmer pack, made by Digital Lighting Systems, will operate properly with the standard 512- byte packet and with the shorter 4-byte DMX packet. Setting S1 to position "0" causes instantaneous transitions between scenes, regardless of the position of S2.

Use a small tip screw driver to rotate the shafts of S1 & S2 to the desired positions.

Standard DMX Packet - S2 set to "0"

DMX Header	Chan. 1	Chan. 2	Chan. 3	Chan. 4	Chan's. 5-512	Idle
------------	---------	---------	---------	---------	---------------	------

Short DMX Packet - S2 set to "F"

DMX Header	Chan. 1	Chan. 2	Chan. 3	Chan. 4	Idle
------------	---------	---------	---------	---------	------

Figure 6 - DMX Output Packet Formats.

S1	Fade Time	S1	Fade Time
0	Instantaneous	0	Instantaneous
1	40.06 Seconds	1	31.63 Seconds
2	37.95 Seconds	2	29.52 Seconds
3	35.84 Seconds	3	27.41 Seconds
4	33.73 Seconds	4	25.30 Seconds
5	31.63 Seconds	5	23.19 Seconds
6	29.52 Seconds	6	21.08 Seconds
7	27.41 Seconds	7	18.98 Seconds
8	25.30 Seconds	8	16.87 Seconds
9	23.19 Seconds	9	14.76 Seconds
A	21.08 Seconds	A	12.65 Seconds
B	18.98 Seconds	B	10.54 Seconds
C	08.43 Seconds	C	08.43 Seconds
D	08.43 Seconds	D	06.33 Seconds
E	08.43 Seconds	E	04.22 Seconds
F	08.43 Seconds	F	02.11 Seconds

Table 1 - Fade Rate  
With S2 set to "0".

Table 2 - Fade Rate  
With S2 set to "F".

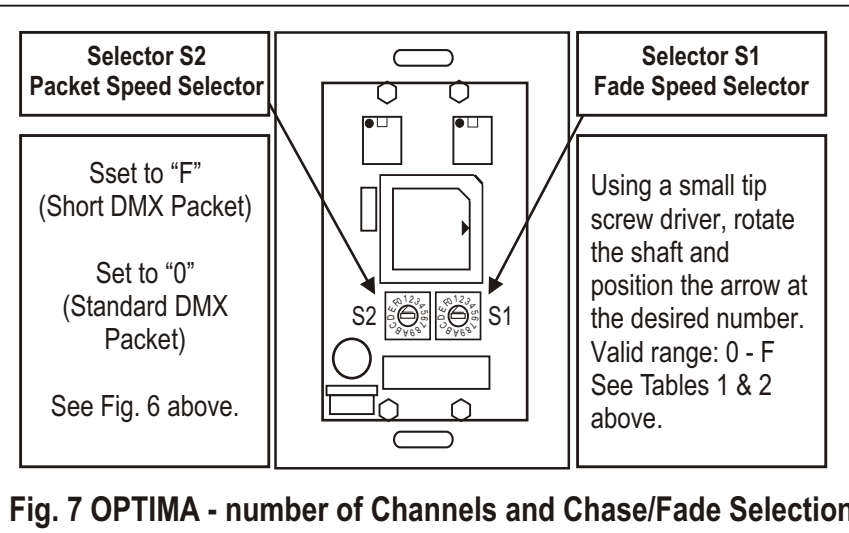

Fig. 7 OPTIMA - number of Channels and Chase/Fade Selection

Should you require any further information regarding the **COMPACT-44D** or **COMPACT-48D** or any other Digital Lighting Systems products, do not hesitate to contact the factory at:

**305-264-8391**

or email at:

**info@digitallighting.com**



Digital Lighting Systems - Lighting Control Excellence since 1978

**WWW.DIGITALLIGHTING.COM**

---



---

## LIMITED WARRANTY

**Digital Lighting Systems**, warrants to the purchaser that its products have been carefully manufactured and inspected and are warranted to be free from defects of workmanship and materials when used as intended. Any abuse or misuse contrary to normal operation shall void this warranty.

Digital Lighting Systems' obligation under this warranty shall be limited to replacement or repair of any units as shall within one year of date of invoice from **Digital Lighting Systems**, prove defective; and **Digital Lighting Systems** shall not be liable for any other damages, whether direct or consequential. **The implied warranties of merchantability and fitness for a particular purpose are limited to the duration of the expressed warranty.** Some states do not allow the exclusion of the limitation of incidental or consequential damages, so the above limitation or exclusion may not apply to you. This warranty gives you specific legal rights, you may also have other legal rights which vary from state to state.

Defective merchandise may be returned to **Digital Lighting Systems**, prepaid, after prior notification has been given and approval obtained for the return. To obtain prior approval for the return of the defective items, contact your local Digital Lighting Systems distributor, representative, or:

### **Digital Lighting Systems, Inc.**

Attn: Customer Service Department  
7588 NW 8th Street  
Miami, FL 33126  
(305) 264-8391

Upon request, replacement unit(s) will be shipped as soon as available. Unless immediate shipment of replacement merchandise is requested, **Digital Lighting Systems** will not ship replacement merchandise until defective merchandise is received, inspected, and determined to be defective.

**No labor charges in connection with warranty problems will be reimbursed by Digital Lighting Systems without prior written approval from the factory.**

**Digital Lighting Systems** distributors and representatives have no authority to change this warranty without written permission.

**Digital Lighting Systems** reserves the right to determine the best method of correcting warranty problems.

---



---



Digital Lighting Systems, Inc.  
7588 NW 8th Street  
Miami, FL 33126  
[www.digitallighting.com](http://www.digitallighting.com)

Tel 305-264-8391  
Fax 305-261-6637  
e-m [info@digitallighting.com](mailto:info@digitallighting.com)

Printed in U.S.A.  
September 2001