



Digital Lighting Systems, Inc.

# PD804

## Eight Channel Dimmer and Switch Packs

# PROTOCOL

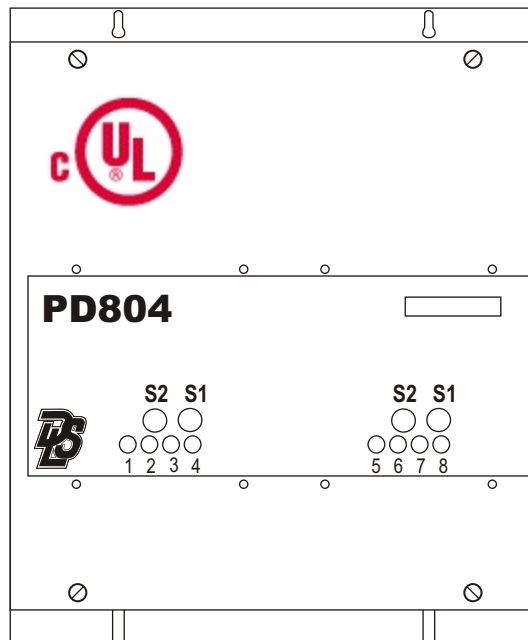

# USER'S MANUAL

## GENERAL DESCRIPTION

The **PD804** is an 8-channel dimmer pack for the **PROTOCOL** lighting control system. The **PD804** dimmer pack contains **8** solid-state dimmers. Power is fed to the **PD804** from **two 20 Amp. breakers on the same electrical phase**. Each breaker feeds four dimmers and each dimmer is rated for a maximum output current of 4 amperes ( **480 Watts at 120 VAC** ). The **PD804** contains three printed circuit boards, the load driver module (**LDM**) and two **INT04** control modules. The dimmers are triggered by the 2 separate firing boards (**INT04's**).

## THE INT04 - (SEE DIAGRAM ON PAGE 2)

The **INT04** is a microprocessor based control board with a nonvolatile memory chip, a communications chip, and a regulated DC power supply. The **INT04** also contains, address selectors, LED output monitors and other support circuitry. The microprocessor is driven by powerful distributed intelligence software which handles all control and communications functions. The **PD804** has two **INT04's**, each one controls four of the eight outputs of the **PD804**. The memory chip on each **INT04** holds all of the **PD804's** pertinent information and settings which include low and high trim levels for each of the four outputs it controls.

The **PD804** does not rely on any shared data source and functions independently of any other system component and without a central system controller. The **PD804** communicates with Protocol system stations and controllers over a **single twisted-pair of wires** and can be connected anywhere on the system network bus. This adds convenience and versatility by allowing **PD804** dimmers to be installed close to their loads and/or service panels.

## THE LDM (LOAD DRIVER MODULE) - (SEE DIAGRAM ON PAGE 2)

The **LDM** is equivalent to eight solid-state relays (**SSR's**) assembled on a single circuit board. The **LDM** is mounted at the bottom of the **PD804's** enclosure which also serves as a heat sink. The relays are triggered by low-voltage signals generated by the **INT04** modules. These signals are optically-isolated by the **LDM** circuitry from all line voltage elements. A step-down 10 VAC- transformer on the **LDM** board supplies power to the **INT04** modules described above.

## OTHER INFORMATION - (SEE DIAGRAM PAGE 4)

Several **PD804** and/or **PD408** and **PD216** dimmer packs may be daisy-chained together in any combination, up to a maximum of 63 individually addressed **INT04's** (each **PD408** and **PD216** has 1x **INT04** each). **PD Dimmers** are daisy-chained using the **RJPD-6** cables (cat5 network cables) supplied with the units. Each **PD804** has two sets of address selectors which must be set to unique addresses. Please see **Table 4** on **Page 9** of this manual or the **PROTOCOL SOFTWARE MANUAL** for more information on addressing the **PD804** dimmer pack.

## DIMMING/SWITCHING - (SEE PAGE 8 FOR MORE INFORMATION)

Through the **PROTOCOL's** "**SOFTPRO**" configuration software, each of the **PD804** outputs may be independently configured not to dim. **PD804** may control any combination of dimmed and switched loads.

There is also a **HARDWARE** lock to ensure circuits do not dim. All four outputs controlled by each **INT04** may be configured not to dim by the installation of a small jumper on the back of the respective **INT04**. This may be done at the factory or in the field.

This jumper may be removed to allow the future dimming of those outputs. Please see **Page 8** for location of this jumper.

Alternatively, the **PD804** may be ordered as a **SWITCH-ONLY** unit, the **PD804-S**. This unit has all the same features as the **PD804** except that there is no dimming, and there are no chokes installed inside the unit. All other information in this manual is the same for both the **PD804** and the **PD804-S**.

**PD804 LOAD DRIVER MODULE INFORMATION**

FIGURE 1 - PD804 LDM DETAIL

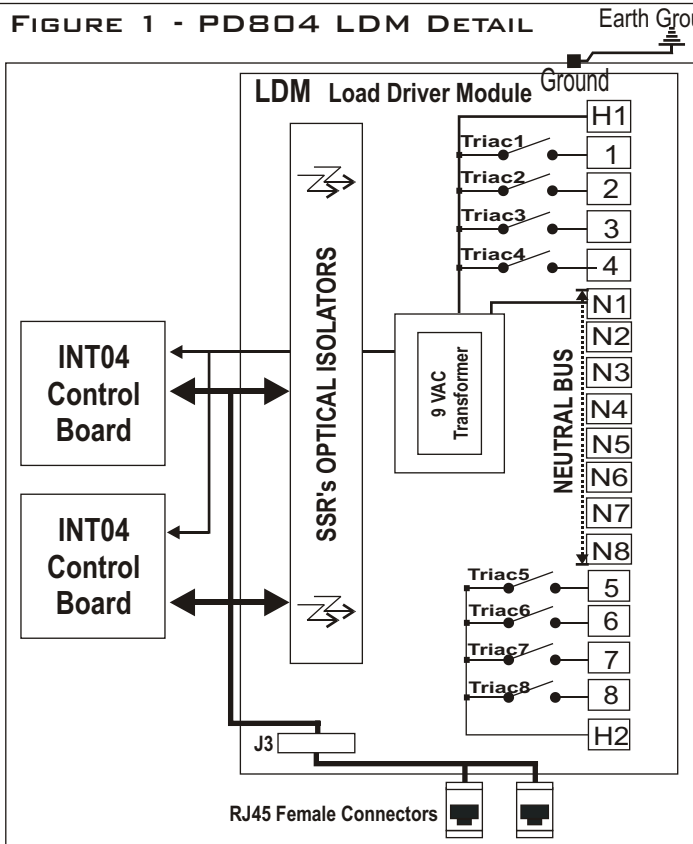

TABLE 1 - TERMINALS DEFINITION

NAME	DESCRIPTION
1	Output Of Solid-State Relay #1
2	Output Of Solid-State Relay #2
3	Output Of Solid-State Relay #3
4	Output Of Solid-State Relay #4
5	Output Of Solid-State Relay #5
6	Output Of Solid-State Relay #6
7	Output Of Solid-State Relay #7
8	Output Of Solid-State Relay #8
H1	Hot Line Feed For Relays 1, 2, 3 & 4
H2	Hot Line Feed For Relays 5, 6, 7 & 8
N1-N8	Neutral Bus Connections.

TABLE 2 - ABSOLUTE MAXIMUM ELECTRICAL RATINGS

Electrical Characteristic	Terminal	Maximum
Relay Load Current	1 to 8	4 Amps.
Input Current For Relays 1 & 2	H1	20 Amps.
Input Current For Relays 3 & 4	H2	20 Amps.
Input Voltage	H1-H2	120 VAC, 1-Phase.

**PD804- INT04 DETAIL**

TABLE 3 - INT04 CIRCUIT LEGEND

- 1 Microprocessor.
  - 2 Nonvolatile Memory.
  - 3 Communications Chip.
  - 4 Quartz Crystal.
  - 5 Power Supply Capacitor.
  - 6 Voltage Regulator.
  - 7 Signal & Power Connector.
  - 8 Output LED Monitors.
  - 9 Jumper for switches only
- S1-S2 Address Selectors.

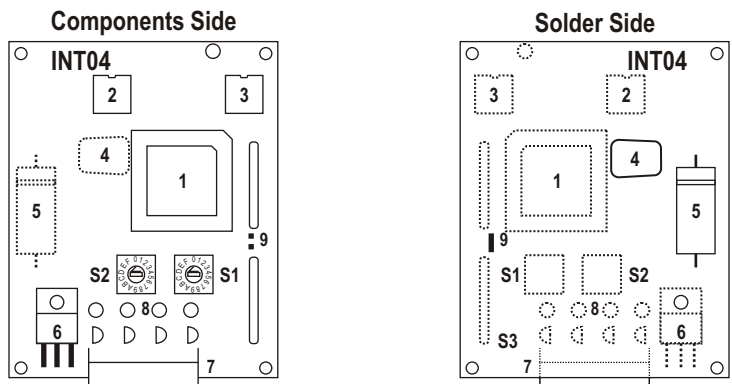

FIGURE 2 - PD804/ INT04 PROTOCOL FIRING BOARD DETAIL

**NOTE:**  
PD804 has two INT04 control boards

**ENCLOSURE INSTALLATION**

Surface mount the dimmer pack in a well ventilated area where the ambient temperature does not exceed 104 F for full load operation. Allow 2" of side clearance for proper air circulation and servicing. Installation clearance shall meet local and/or NEC code requirements. Enclosures may be attached to the wall or other mounting surface by holes in the heat sink flanges. Refer to the drawings below (FIGURE 3) for the correct dimensions. Conduit shall be pulled to the top of the dimmer packs.

**NOTE**

The PD804 may create a slight buzzing noise and should not be located where this is objectionable.

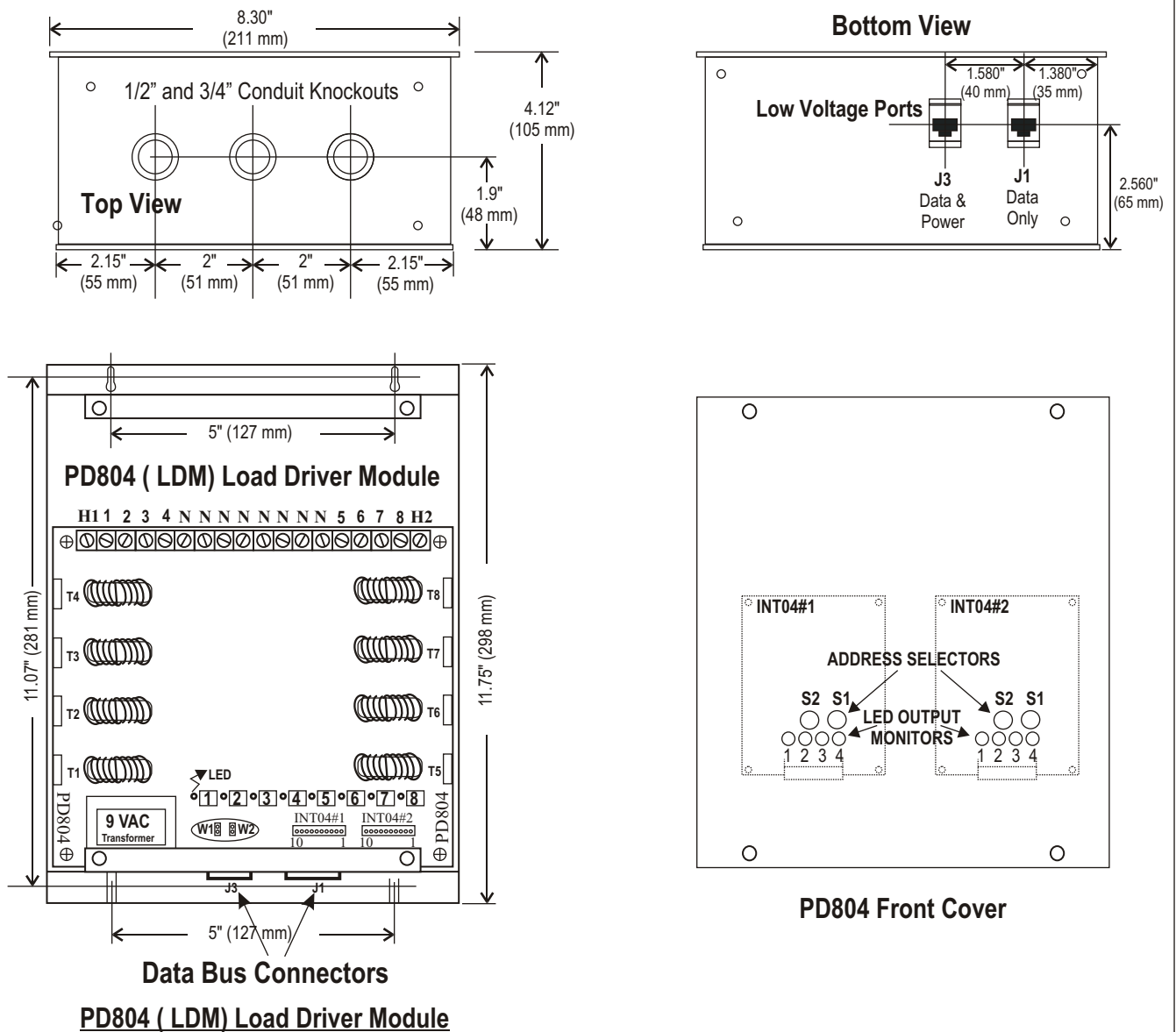

**FIGURE 3 - PD804 DIMENSIONAL DIAGRAM**

**PD804 LOW VOLTAGE WIRING METHODS**

**W1-W2 Shunt Jumpers**

Protocol systems with 3 control nodes or less (**PS Series** stations, **DCO**, **DCI** or **RAU**) do not require an external power supply transformer. Power for these components can be supplied by one of the **PD804** dimmer packs. *Figure 4* shows the **PD804's** network ports with its pin assignments. Installing W1 and W2 connects the 9 VAC transformer output to the network bus via J3. The 9 VAC output is permanently connected to J1. *Figure 5* shows a typical small system with one **PD Dimmer** supplying power to the network. *Figure 6* shows a typical system with an external transformer. System accessories such as extension cables and jumper boards are available from DLS and can simplify network bus connections.

**TO AVOID PARALLELING THE OUTPUTS OF SEVERAL TRANSFORMERS IN A PROTOCOL SYSTEM:**

- ⊗ Do not install the jumpers in any of the PD Dimmers when a DB44 panel with an external transformer is used in a system.
- ⊗ Do not install jumpers in more than one PD Dimmer per system when no external transformer is used.

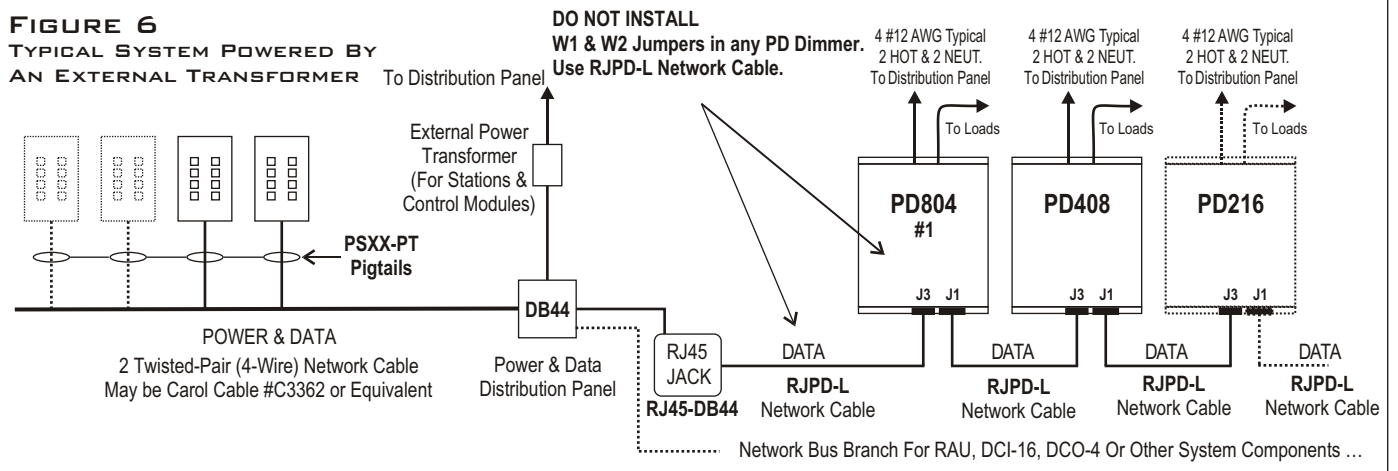
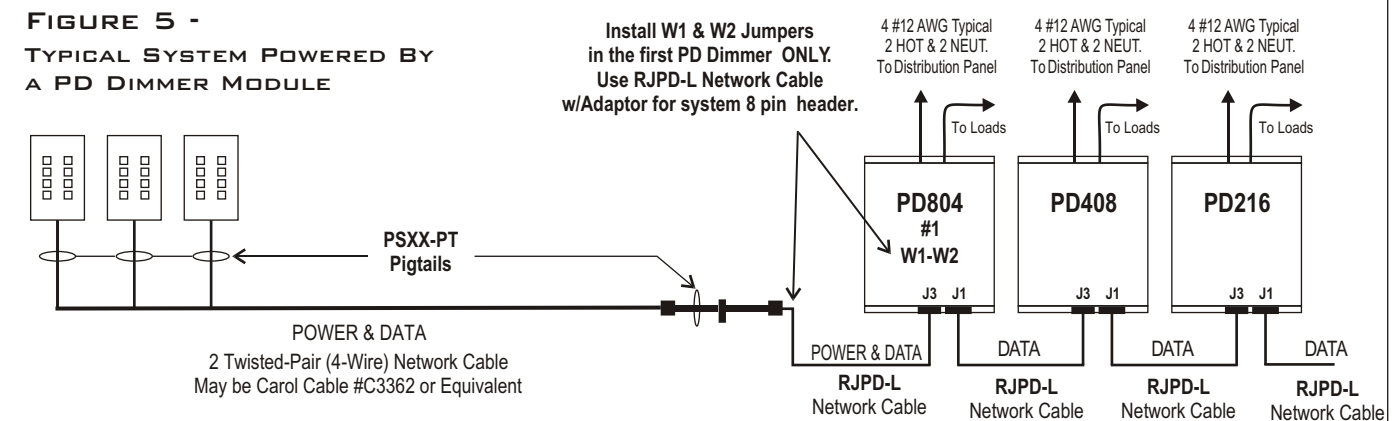
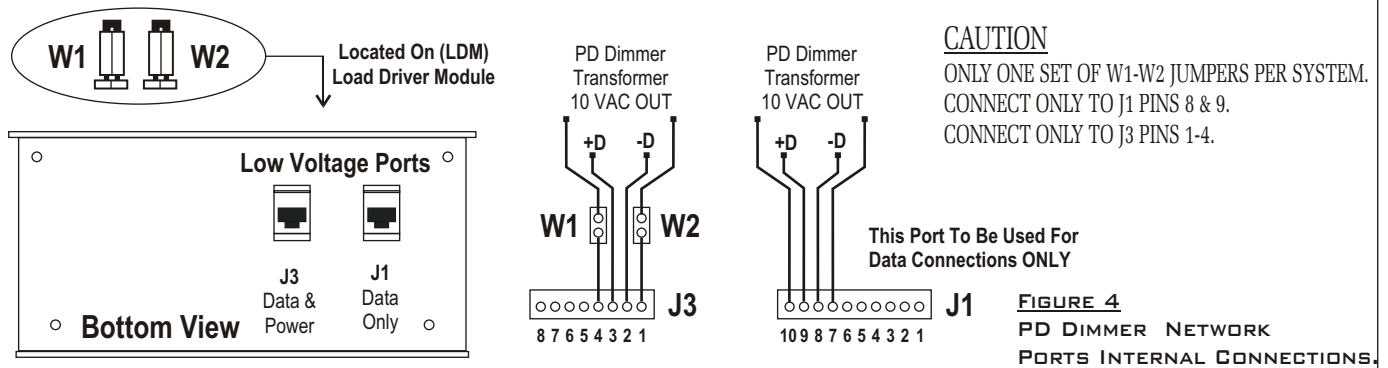

**PD804 GENERAL WIRING INSTRUCTIONS**

**WIRING NOTES**

- DO NOT EXCEED 480 W (4 Amps. ) per dimmer output @ 120VAC.
- All wiring between the control stations, dimmers, and other system controllers (network bus) is low voltage (NEMA Class 2) and may be run with two, twisted pair, shielded #18 AWG wire. Control network bus may be Carol Cable #C3362 unless otherwise required. Consult the PROTOCOL Hardware Installation Manual, Appendix E, for maximum wire length.
- PD804 dimmer packs may be fed by one or two 20 A (maximum) branch circuits and may have up to eight separately dimmed loads.
- **Both breakers must be on the same power phase.**
- **CAUTION: DO NOT** attempt to parallel outputs to increase capacity.
- Installations must conform to local and/or NEC code requirements.
- Each load must have its own Neutral wire for full load operation.
- All line voltage wires must have copper conductors of adequate Gauge with 90 C wire insulation.
- POWER EACH LOAD DIRECTLY BEFORE CONNECTING IT TO THE PD804, TO ENSURE PROPER WIRING.

**FIGURE 7 - PD804 TYPICAL 120 VAC WIRING.**

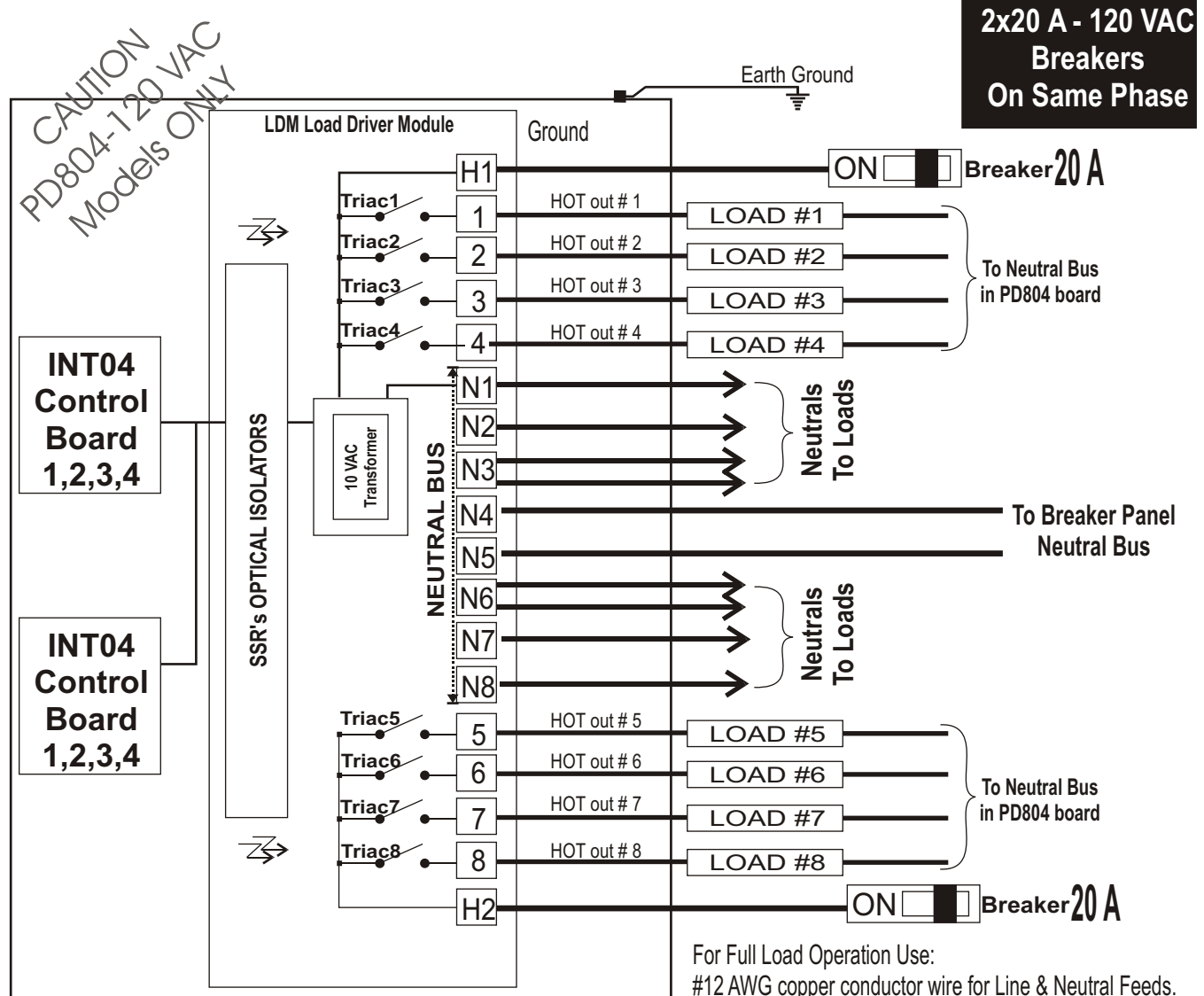

For Full Load Operation Use:  
 #12 AWG copper conductor wire for Line & Neutral Feeds.  
 #14 AWG copper conductors in/out to each load.  
 Max. Load per circuit : 4 Amperes (480W at 120 VAC).

**PD804-220 GENERAL WIRING INSTRUCTIONS**

**WIRING NOTES**

- DO NOT EXCEED 960 W (4 Amps. ) per dimmer output @ 240VAC.
- All wiring between the control stations, dimmers, and other system controllers (network bus) is low voltage (NEMA Class 2) and may be run with two, twisted pair, shielded #18 AWG wire. Control network bus may be Carol Cable #C3362 unless otherwise required. Consult the PROTOCOL Hardware Installation Manual, Appendix E, for maximum wire length.
- PD804 dimmer packs may be fed by one or two 20 A (maximum) branch circuits and may have up to eight separately dimmed loads.
- **Both breakers must be on the same power phase.**
- **CAUTION: DO NOT** attempt to parallel outputs to increase capacity.
- Installations must conform to local and/or NEC code requirements.
- Each load must have its own Neutral wire for full load operation.
- All line voltage wires must have copper conductors of adequate Gauge with 90 C wire insulation.
- POWER EACH LOAD DIRECTLY BEFORE CONNECTING IT TO THE PD804, TO ENSURE PROPER WIRING.

**FIGURE 8 - PD804 TYPICAL 220/240 VAC WIRING.**

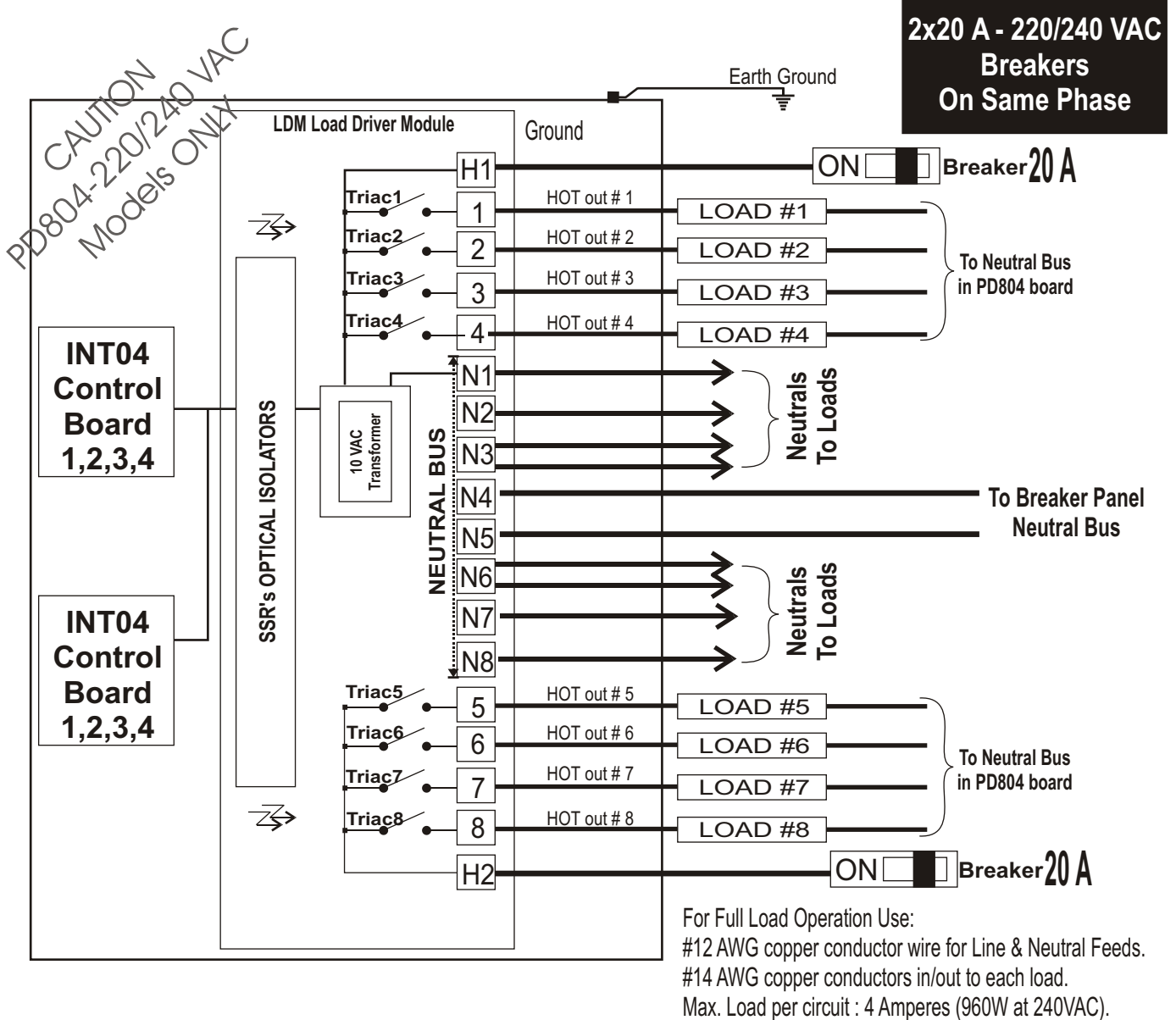

For Full Load Operation Use:  
 #12 AWG copper conductor wire for Line & Neutral Feeds.  
 #14 AWG copper conductors in/out to each load.  
 Max. Load per circuit : 4 Amperes (960W at 240VAC).

**FIGURE 9 - PD804-24/12 LOW VOLTAGE LOAD AND POWER WIRING**

**CAUTION**  
 PD804-24  
 PD804-12  
 Models ONLY

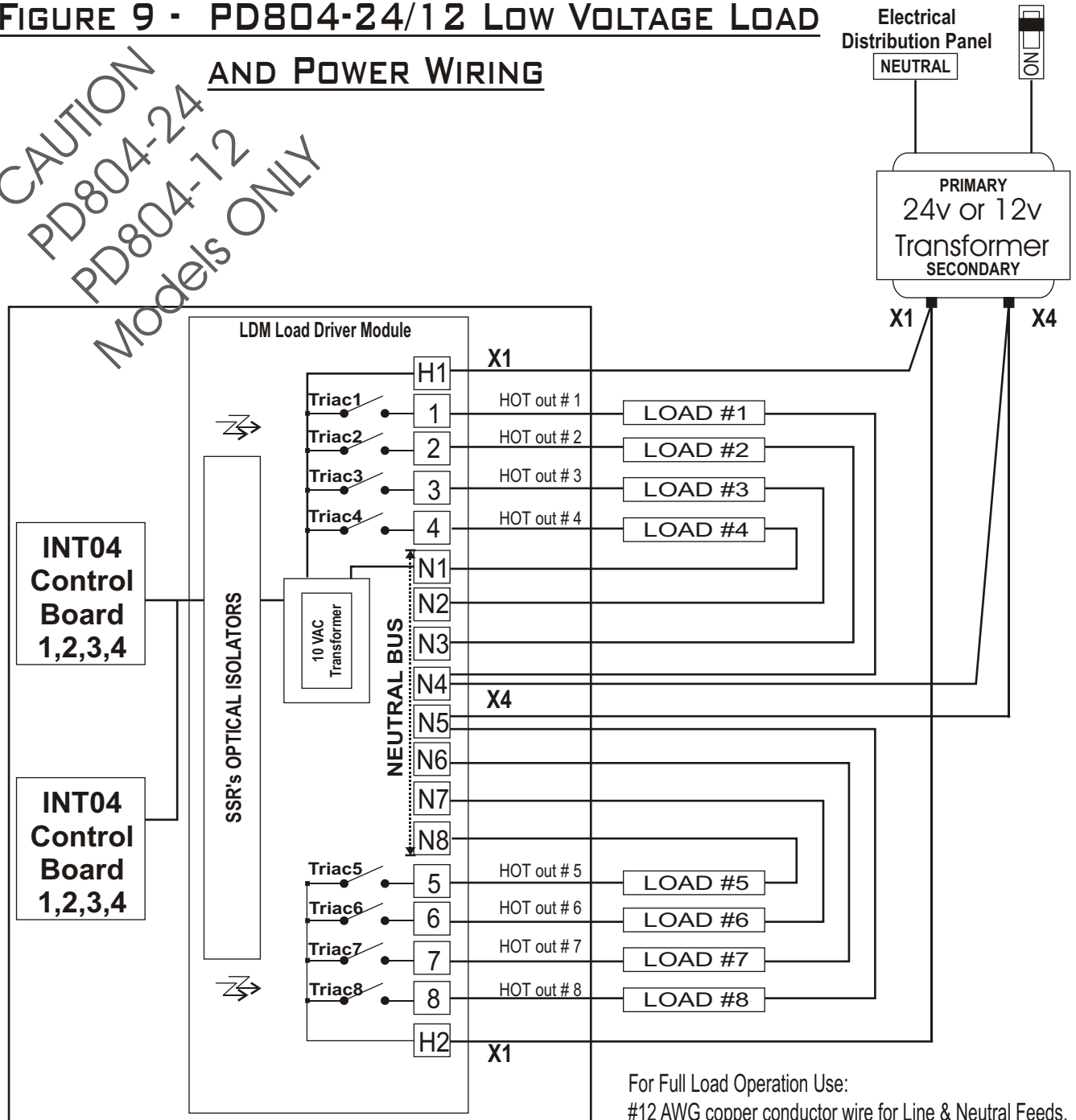

For Full Load Operation Use:  
 #12 AWG copper conductor wire for Line & Neutral Feeds.  
 #14 AWG copper conductors in/out to each load.  
 Max. Load per circuit : 4 Amperes (96W at 24 VAC).

**NOTES**

- 1 With PD804-24 you may use a single 24 VAC-800 VA or better transformer or two separate 24 VAC-400 VA or better transformers.
- 2 With PD804-12 you may use a single 12 VAC-400 VA or better transformer or two separate 12 VAC-200 VA or better transformers.
- 3 Follow transformer's installation & wiring instructions from manufacturer.
- 4 Maximum Load Per Output: 48 Watts at 12 VAC.
- 5 Maximum Load Per Output: 96 watts at 24 VAC.



**PROTOCOL ADDRESS SETTING**

Up to 63 uniquely addressed INT04 boards (two in each PD804, one in each PD408 and PD216) may be installed in any one system. Each INT04 must be set to a unique decimal address between 1 and 63. INT04 #63 output 4 is not available for use. Total number of zones ((63 x 4) - 1 = 251). Refer to TABLE 4 On Page 9 of this manual for proper setting of the address selectors S1 and S2 on the PD804.

**Example:**

S2 & S1 should be set respectively to 1 & A if the desired address is 26 (1 x 16 + A = 26, A=10). In this example, outputs 1 through 4 of PD804 INT04 # 1 are referred to as 26.1, 26.2, 26.3 and 26.4 when configuring buttons on PROTOCOL stations, using the PROTOCOL "SOFTPRO" programming software. Outputs 1 through 4 of INT04 # 2 are addressed in the same manner using a different address (may be a consecutive address, i.e. 27 but may be any address not yet used in the system).

**NOTE:**

It is also possible to quadruple the maximum number of outputs on a system up to 1004 circuits. An INT04 may have a decimal address of up to, and including, 252. Please contact factory for more details. For a complete Decimal to Hexadecimal conversion chart, please refer to Appendix A in the PROTOCOL Hardware and Software Manuals.

**NON-DIM OUTPUT SETTING**

All four outputs controlled by each INT04 in the PD804 may be configured for non-dim (switch only) operation by a hardware lock. This prevents inadvertent dimming, or damage, of loads that cannot be dimmed, such as contactors, mechanical relays, motors, non-dim fluorescent, etc...

Since this procedure involves adding a jumper to the INT04 board, it is preferable to have it performed by the factory, at time of order. However, any qualified electronic technician can perform the procedure in the field when necessary. Figure 10 shows the location for installing the non-dim (ND) jumper.

As there are two INT04's per PD804, this procedure may be applied to either INT04, both, or neither. This will allow a PD804 to have either all eight outputs dimmable, all eight non-dimmable, or to have four outputs dimmable and four outputs, with the hardware lock, non-dimmable.

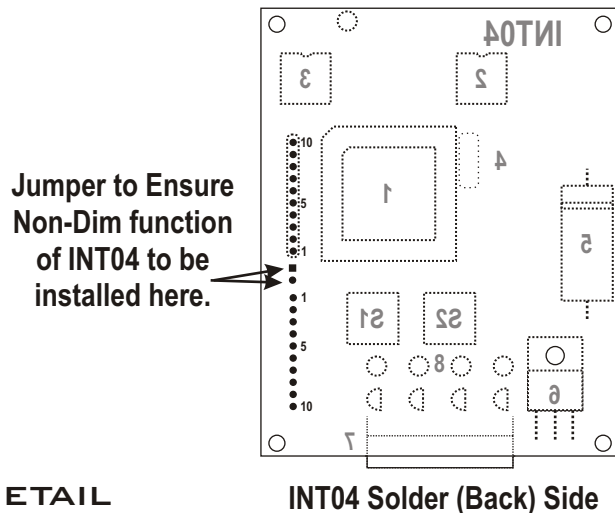

FIGURE 10 - PD804 INT04 DETAIL

**PD804 INSTALLATION CHECK LIST**

**BEFORE ENERGIZING THE PD804 MAKE SURE:**

- Loads are tested before connecting to dimmers.
- Breaker feed lines are on same electrical phase.
- PD804 has been properly grounded.
- All line voltage screw terminals are properly tightened to prevent hot spots.
- Low voltage data lines connections are properly insulated.
- Low voltage data lines polarity is observed throughout the system.
- The PD804's INT04's are set to the right addresses.
- ALL KNOCKOUT HOLES MUST BE COVERED WHEN UNIT IS INSTALLED

Table 4 - PD804 Address Selection Information

<b>00</b>	<b>INVALID ADDRESS</b>	<b>33</b>	set S2,S1 to <b>2,1</b>
<b>01</b>	set S2,S1 to <b>0,1</b>	<b>34</b>	set S2,S1 to <b>2,2</b>
<b>02</b>	set S2,S1 to <b>0,2</b>	<b>35</b>	set S2,S1 to <b>2,3</b>
<b>03</b>	set S2,S1 to <b>0,3</b>	<b>36</b>	set S2,S1 to <b>2,4</b>
<b>04</b>	set S2,S1 to <b>0,4</b>	<b>37</b>	set S2,S1 to <b>2,5</b>
<b>05</b>	set S2,S1 to <b>0,5</b>	<b>38</b>	set S2,S1 to <b>2,6</b>
<b>06</b>	set S2,S1 to <b>0,6</b>	<b>39</b>	set S2,S1 to <b>2,7</b>
<b>07</b>	set S2,S1 to <b>0,7</b>	<b>40</b>	set S2,S1 to <b>2,8</b>
<b>08</b>	set S2,S1 to <b>0,8</b>	<b>41</b>	set S2,S1 to <b>2,9</b>
<b>09</b>	set S2,S1 to <b>0,9</b>	<b>42</b>	set S2,S1 to <b>2,A</b>
<b>10</b>	set S2,S1 to <b>0,A</b>	<b>43</b>	set S2,S1 to <b>2,B</b>
<b>11</b>	set S2,S1 to <b>0,B</b>	<b>44</b>	set S2,S1 to <b>2,C</b>
<b>12</b>	set S2,S1 to <b>0,C</b>	<b>45</b>	set S2,S1 to <b>2,D</b>
<b>13</b>	set S2,S1 to <b>0,D</b>	<b>46</b>	set S2,S1 to <b>2,E</b>
<b>14</b>	set S2,S1 to <b>0,E</b>	<b>47</b>	set S2,S1 to <b>2,F</b>
<b>15</b>	set S2,S1 to <b>0,F</b>	<b>48</b>	set S2,S1 to <b>3,0</b>
<b>16</b>	set S2,S1 to <b>1,0</b>	<b>49</b>	set S2,S1 to <b>3,1</b>
<b>17</b>	set S2,S1 to <b>1,1</b>	<b>50</b>	set S2,S1 to <b>3,2</b>
<b>18</b>	set S2,S1 to <b>1,2</b>	<b>51</b>	set S2,S1 to <b>3,3</b>
<b>19</b>	set S2,S1 to <b>1,3</b>	<b>52</b>	set S2,S1 to <b>3,4</b>
<b>20</b>	set S2,S1 to <b>1,4</b>	<b>53</b>	set S2,S1 to <b>3,5</b>
<b>21</b>	set S2,S1 to <b>1,5</b>	<b>54</b>	set S2,S1 to <b>3,6</b>
<b>22</b>	set S2,S1 to <b>1,6</b>	<b>55</b>	set S2,S1 to <b>3,7</b>
<b>23</b>	set S2,S1 to <b>1,7</b>	<b>56</b>	set S2,S1 to <b>3,8</b>
<b>24</b>	set S2,S1 to <b>1,8</b>	<b>57</b>	set S2,S1 to <b>3,9</b>
<b>25</b>	set S2,S1 to <b>1,9</b>	<b>58</b>	set S2,S1 to <b>3,A</b>
<b>26</b>	set S2,S1 to <b>1,A</b>	<b>59</b>	set S2,S1 to <b>3,B</b>
<b>27</b>	set S2,S1 to <b>1,B</b>	<b>60</b>	set S2,S1 to <b>3,C</b>
<b>28</b>	set S2,S1 to <b>1,C</b>	<b>61</b>	set S2,S1 to <b>3,D</b>
<b>29</b>	set S2,S1 to <b>1,D</b>	<b>62</b>	set S2,S1 to <b>3,E</b>
<b>30</b>	set S2,S1 to <b>1,E</b>	<b>63</b>	set S2,S1 to <b>3,F</b>
<b>31</b>	set S2,S1 to <b>1,F</b>		
<b>32</b>	set S2,S1 to <b>2,0</b>		

**NOTES:**

00 Decimal (S2,S1 = 0,0) is not allowed on any device.

Max **INT04** Address: 63 Decimal (S2,S1 = 3,F)



---

## LIMITED WARRANTY

**Digital Lighting Systems**, warrants to the purchaser that its products have been carefully manufactured and inspected and are warranted to be free from defects of workmanship and materials when used as intended. Any abuse or misuse contrary to normal operation shall void this warranty.

Digital Lighting Systems' obligation under this warranty shall be limited to replacement or repair of any units as shall within two years of date of invoice from **Digital Lighting Systems**, prove defective; and **Digital Lighting Systems** shall not be liable for any other damages, whether direct or consequential. **The implied warranties of merchantability and fitness for a particular purpose are limited to the duration of the expressed warranty.** Some states do not allow the exclusion of the limitation of incidental or consequential damages, so the above limitation or exclusion may not apply to you. This warranty gives you specific legal rights, you may also have other legal rights which vary from state to state.

Defective merchandise may be returned to **Digital Lighting Systems**, prepaid, after prior notification has been given and approval obtained for the return. To obtain prior approval for the return of the defective items, contact your local Digital Lighting Systems distributor, representative, or:

### **Digital Lighting Systems, Inc.**

Attn: Customer Service Department  
7588 NW 8th Street  
Miami, FL 33126  
(305) 264-8391

Upon request, replacement unit(s) will be shipped as soon as available. Unless immediate shipment of replacement merchandise is requested, **Digital Lighting Systems** will not ship replacement merchandise until defective merchandise is received, inspected, and determined to be defective.

**No labor charges in connection with warranty problems will be reimbursed by Digital Lighting Systems without prior written approval from the factory.**

**Digital Lighting Systems** distributors and representatives have no authority to change this warranty without written permission.

**Digital Lighting Systems** reserves the right to determine the best method of correcting warranty problems.





Digital Lighting Systems, Inc.  
7588 NW 8th Street  
Miami, FL 33126  
[www.digitallighting.com](http://www.digitallighting.com)

Tel 305-264-8391  
Fax 305-261-6637  
e-m [info@digitallighting.com](mailto:info@digitallighting.com)

Printed in U.S.A.  
April 2002