

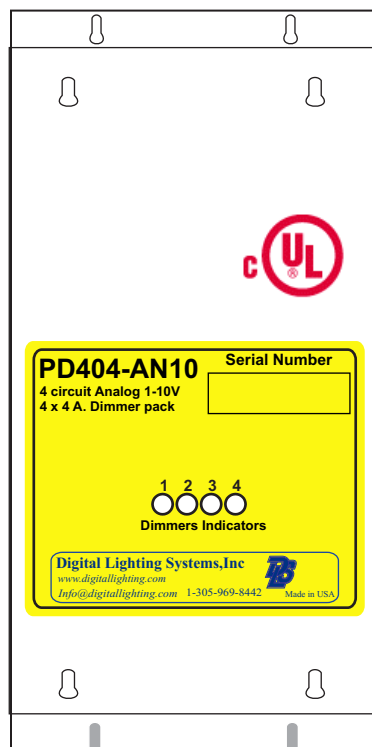

# PD404-AN10

0-10V analog control  
4 Channel x 500 W Dimmer & Switch Packs

## ANALOG 0-10 V



## USER'S MANUAL



**PD404-AN10 Load Driver Module Information**

Figure 1 - PD404 LDM Detail

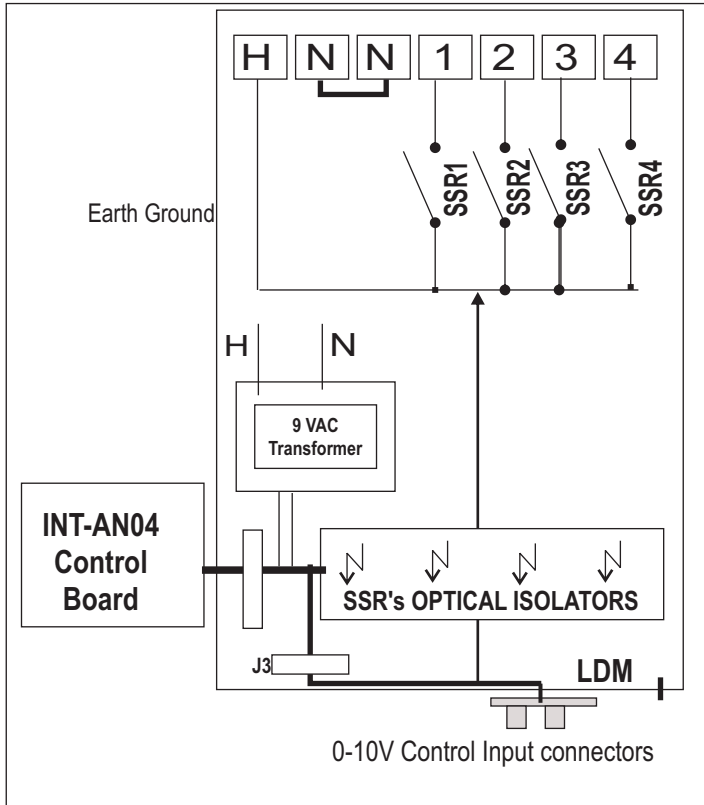

Table 1 - Terminals Definition

NAME	DESCRIPTION
1	Output Of Solid-State Relay #1
2	Output Of Solid-State Relay #2
3	Output Of Solid-State Relay #3
4	Output Of Solid-State Relay #4
H	Hot Line Feed For Relays 1 , 2 , 3 & 4.
N	Neutral Bus Connections.

Table 2 - Absolute Maximum Electrical Ratings

**Electrical Characteristic Terminal Maximum**

Relay Load Current	1 to 4	4 Amps.
Input Current	H	20 Amps.
Input Voltage	H	120 VAC

**Specifications: PD404-AN10**

4 x 500 Watts @ 120 VAC dimmer pack which is designed to be controlled either by a 4 x100 KOHM potentiometers ; one for each dimmer, or by a standard **0-10 V analog signal from a sinking or sourcing controller.**

**Control Input specifications:**

1 mA. current; Response range :  
1 V = 0% ; 10 V = 100 %

**Dimmer power specifications:**

Operating Voltage: 120 VAC  
Input : 1 x 20 Amp Breaker  
Outputs: 4 x 500 Watts

Figure 2 - INT-AN04 control board

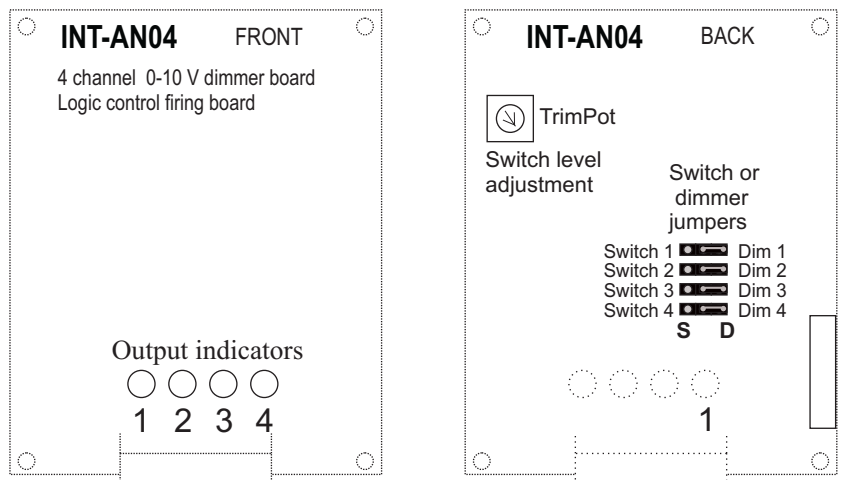

Each channel of the PD404-AN10 could be set to dim or switch. 4 Jumpers, 1 for each channel, are located on the back of the front cover. Place jumper on D side for normal 0-10V dimmer operation, place jumper on S side for switch operation. Switching control Voltage level could be set from 0 to 10 V with the TrimPot.

**Enclosure Installation**

Surface mount the dimmer pack in a well ventilated area where the ambient temperature does not exceed 104° F for full load operation. Allow 2" of side clearance for proper air circulation and servicing. Installation clearance shall meet local and/or NEC code requirements. Enclosures may be attached to the wall or other mounting surface by holes in the heat sink flanges. Refer to the drawings below (FIGURE 3) for the correct dimensions. Conduit shall be pulled to the top of the dimmer packs.

**Figure 3 - PD404-AN10 Dimensional Diagram**

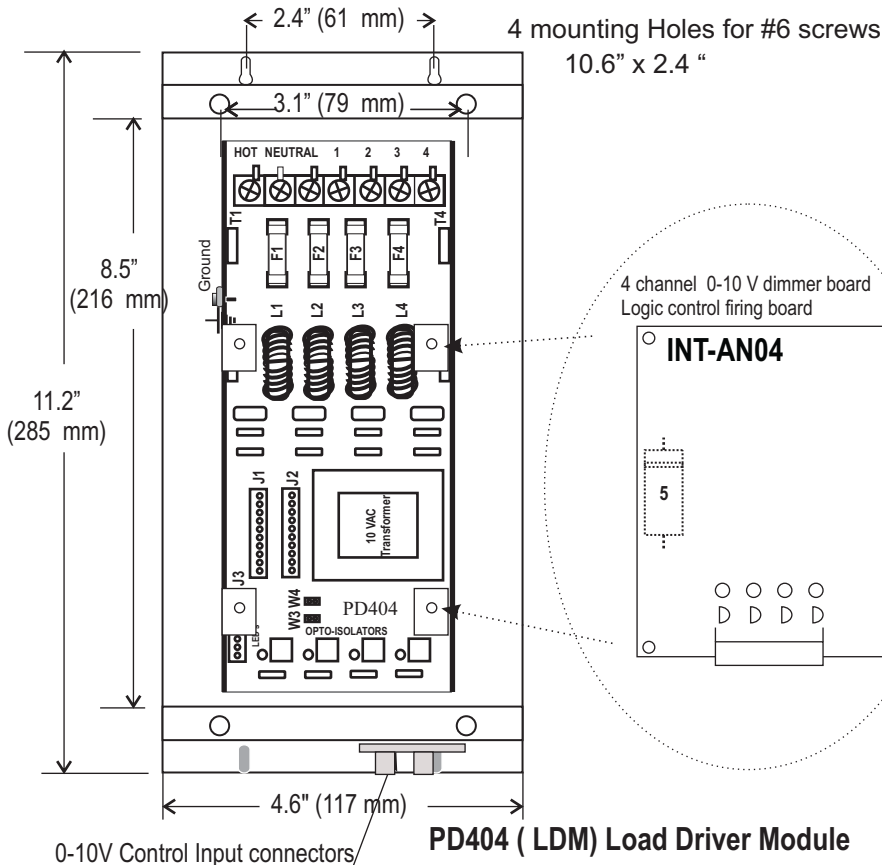
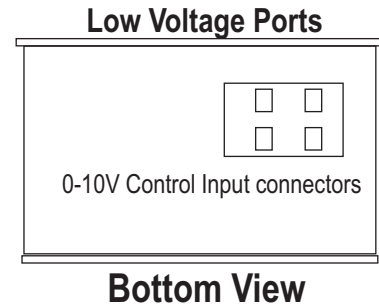
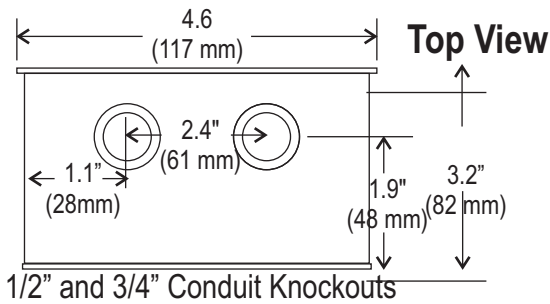

**PD404-AN10 General Wiring Instructions**

**Wiring Notes**

- ❑ **DO NOT EXCEED 480 W (4 Amps. ) per each dimmer @ 120VAC.**
- ❑ All wiring From control to dimmers is low voltage (NEMA Class 2)
- ❑ **PD404-AN10** dimmer packs may be fed by one 20 A (maximum) branch circuit and may have up to Four separately dimmed loads.
- ❑ **CAUTION: DO NOT** attempt to parallel outputs to increase capacity.
- ❑ Installations must conform to local and/or NEC code requirements.
- ❑ Each load must have its own Neutral wire for full load operation.
- ❑ All line voltage wires must have copper conductors of adequate Gauge with 90° C wire insulation.
- ❑ **POWER EACH LOAD DIRECTLY BEFORE CONNECTING IT TO THE PD404-AN10 TO ENSURE PROPER WIRING.**

**Figure 4 - PD404-AN10 Typical Control Wiring.**

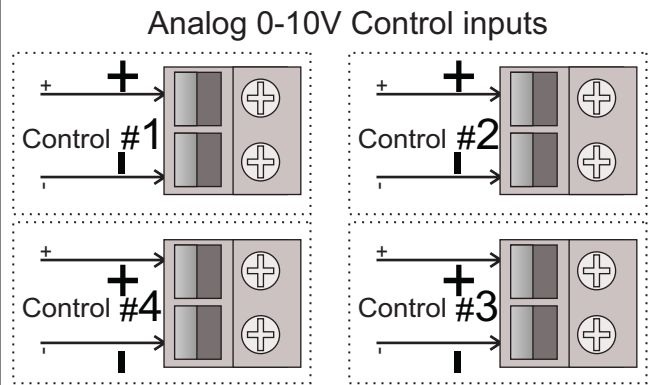

Optional:  
 Could be also controlled with 4x 100 KOHM potentiometers .

**Figure 5 - PD404-AN10 Typical 120 VAC Wiring.**

From Electrical  
 Distribution Panel

**1x20 A - 120 VAC  
 Breaker**

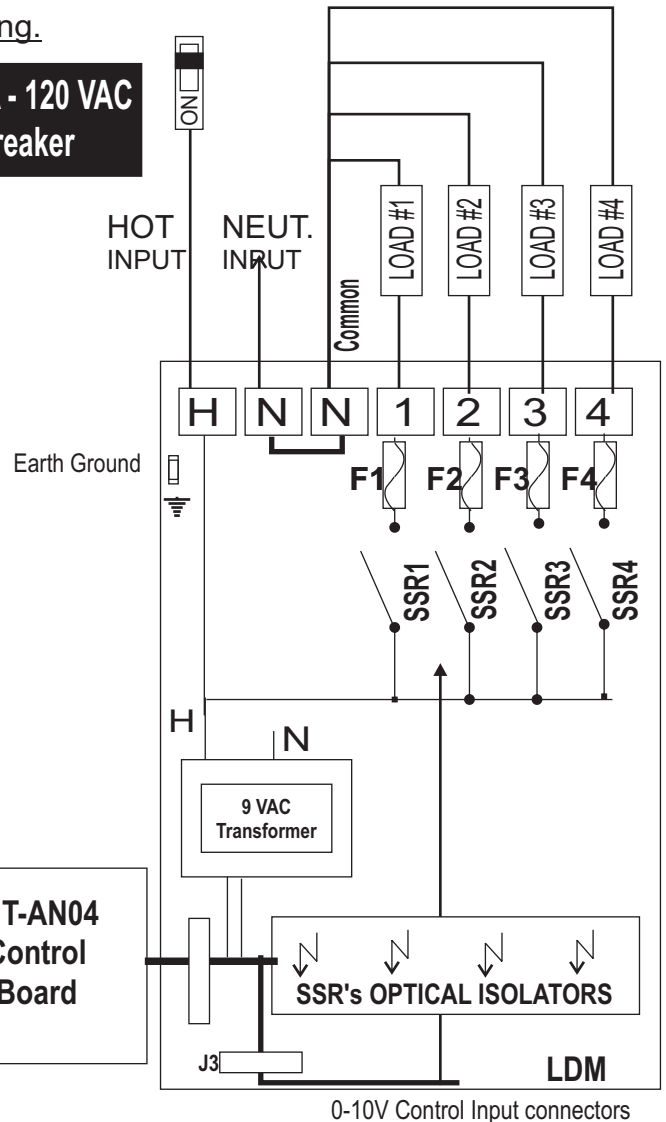

**CAUTION:**

**Fuses 1 to 4 are  
 5 Amps/250V ; quick blow  
 to be replaced  
 by certified electrician.**

For Full Load Operation Use:  
 #12 AWG copper conductor wire  
 for Line & Neutral Feeds.  
 #14 AWG copper conductors  
 to each load.  
 Follow N.E.C. requirements  
 Max. Per Load: 4 Amperes  
 (480 W at 120 VAC).



## LIMITED WARRANTY

**Digital Lighting Systems**, warrants to the purchaser that its products have been carefully manufactured and inspected and are warranted to be free from defects of workmanship and materials when used as intended. Any abuse or misuse contrary to normal operation shall void this warranty.

Digital Lighting Systems' obligation under this warranty shall be limited to replacement or repair of any units as shall within two years of date of invoice from **Digital Lighting Systems**, prove defective; and **Digital Lighting Systems** shall not be liable for any other damages, whether direct or consequential. **The implied warranties of merchantability and fitness for a particular purpose are limited to the duration of the expressed warranty.** Some states do not allow the exclusion of the limitation of incidental or consequential damages, so the above limitation or exclusion may not apply to you. This warranty gives you specific legal rights, you may also have other legal rights which vary from state to state.

Defective merchandise may be returned to **Digital Lighting Systems**, prepaid, after prior notification has been given and approval obtained for the return. To obtain prior approval for the return of the defective items, contact your local Digital Lighting Systems distributor, representative, or:

### **Digital Lighting Systems, Inc.**

Attn: Customer Service Department  
12302 SW 128 Ct. Bay #105  
Miami, FL 33186  
(305) 969-8442



Digital Lighting Systems, Inc.  
12302 SW 128 Ct.  
Miami, FL 33186  
[www.digitallighting.com](http://www.digitallighting.com)

Tel 305-969-8442  
Fax 305-969-8675  
e-m [info@digitallighting.com](mailto:info@digitallighting.com)

Upon request, replacement unit(s) will be shipped as soon as available. Unless immediate shipment of replacement merchandise is requested, **Digital Lighting Systems** will not ship replacement merchandise until defective merchandise is received, inspected, and determined to be defective.

**No labor charges in connection with warranty problems will be reimbursed by Digital Lighting Systems without prior written approval from the factory.**

**Digital Lighting Systems** distributors and representatives have no authority to change this warranty without written permission.

**Digital Lighting Systems** reserves the right to determine the best method of correcting warranty problems.

